

Locating Multiphase, Multisection Faults in Capacitor Banks

Dereje Jada Hawaz and Satish Samineni, Schweitzer Engineering Laboratories, Inc.
Brian K. Johnson, University of Idaho

Abstract—Locating faulty units in shunt capacitor banks (SCBs) and replacing them in a timely manner enhance the overall benefits of delivering efficient electrical power. This paper presents a multiphase, multisection fault-locating approach for ungrounded single- or double-wye capacitor banks that use neutral voltage and neutral current monitoring devices (i.e., instrument transformers). The fault-locating solution can identify simultaneous and evolving faults in multiphases of single-wye arrangements or in two different sections of the bank in double-wye arrangements. The method can be easily realized in relays with a programming logic capability. In this paper, the proposed solution is presented, and simulation results obtained from a real-time digital simulator (RTDS) are discussed to demonstrate and verify the solution.

I. INTRODUCTION

Shunt capacitor banks (SCBs) play an essential role in enhancing power system capacity [1]. They accomplish this by performing local reactive power support and reducing line currents, thereby improving the power system capacity. SCBs are the most economically suitable devices to improve power system capacity at both the transmission and distribution levels. Increasing system capacity means a postponement of new system expansion, such as new generation and transmission capacity.

As with any essential power system asset, SCBs need to be protected. Protective relays are used to monitor bank unbalance caused by capacitor element and unit failures, generating alarms for a tolerable number of capacitor failures and tripping the bank to prevent cascading failures.

One important aspect of bringing SCBs back into service is locating the failed capacitor units and replacing them. A manual fault-locating process is typically required, prolonging the repair time.

A recently developed solution [2] that has grown in popularity identifies faulted phases or sections of SCBs to help utility crews pinpoint the location of faulted capacitors for speedy maintenance. However, the method is limited to locating failed capacitors in one phase only for single-wye banks or one section only for double-wye banks. If a failure occurs in one phase and a second failure occurs in a different phase, then the fault location accuracy is compromised, the first failure indicator is lost unless it is already noted, and the method is rearmed again.

This paper presents the multiphase, multisection fault location solution that is based on the existing single-phase, single-section fault location method on ungrounded single-wye and double-wye arranged banks. The presented solution does not require additional equipment in the substation, and its

benefit can be realized in relays with logic capabilities to be programmed and applied.

In this paper, Sections II and III review the SCB configuration and capacitor unbalance protection. The existing fault location solution is described in Section IV. The proposed multiphase, multisection fault location solution is then presented in Section V, followed by simulation results in Section VI.

II. SHUNT CAPACITOR BANK CONFIGURATION

SCBs have several single-phase capacitor units that are connected in series and parallel, as shown in Fig. 1, to meet the voltage and volt-ampere reactive (VAR) rating of the bank. The number of capacitor units that are being connected in parallel or series is an important consideration of capacitor bank configuration and protection.

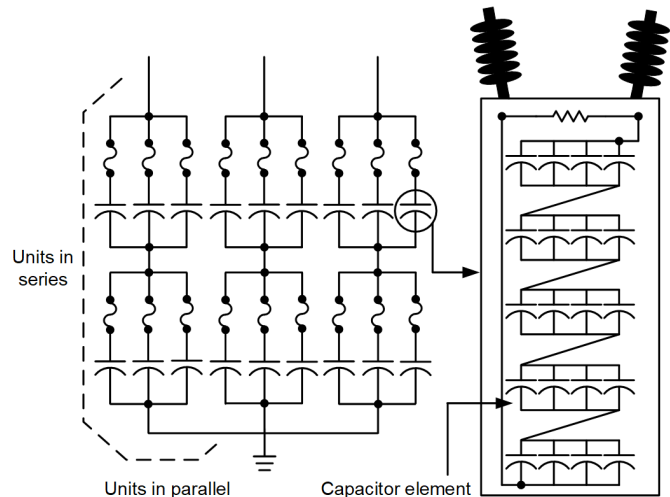

Fig. 1. Typical substation installation of shunt capacitor bank.

The loss of dielectric causes capacitor elements to permanently short. This results in exerting overvoltage on the remaining healthy capacitor elements and can lead to more element failures. Fuses can prevent successive element failures by isolating the shorted element or unit.

There are three types of fusing for SCBs:

- Externally fused
- Internally fused
- Fuseless

Externally fused SCBs have fuses that are connected outside of capacitor unit cases. External fuses remove the entire capacitor unit from the bank to prevent a case rupture and keep the remaining units operational. Externally fused banks are beneficial in returning the failed capacitor unit to service

quicker because identifying the fault location can be achieved by a simple visual inspection.

Internally fused SCBs use capacitor units that have internal fuses for each capacitor element. Unlike an externally fused SCB, there is no visual indication, so it takes longer to locate the faulty units.

Fuseless SCBs have no external fuses installed and do not use internally fused capacitor units. Because of that, when a unit fails, the damage is permanent. Like internally fused SCBs, fault location cannot be achieved through visual inspection, resulting in longer maintenance time. Modern SCBs are mostly fuseless banks; hence, the need for fault location becomes apparent for reducing downtime.

SCBs are connected in several ways, depending on the utility requirements and practices. Most of the time the requirements are dictated by economics and protection philosophy. SCBs can be connected as a single or double wye or H-bridge. SCBs can be grounded or ungrounded. Some of the most common connections in the SCBs are shown in Fig. 2.

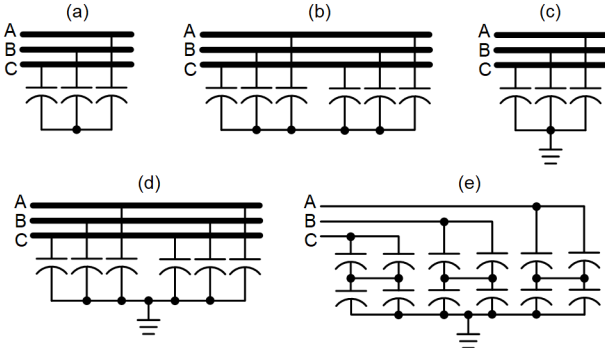

Fig. 2. Common capacitor bank connections include an (a) ungrounded single wye, (b) ungrounded double wye, (c) grounded single wye, (d) grounded double wye, and (e) H-bridge configuration.

III. SHUNT CAPACITOR BANK PROTECTION

Unbalance protection detects unbalance currents or voltages caused by unit or element failures within SCBs and alarms if the unbalance is small but trips if the unbalance is big enough, thereby preventing a cascading failure. The reliability of unbalance protection depends on the SCB configuration.

The four commonly used unbalance protection methods for the capacitor bank are as follows [2] [3] [4]:

- Phase voltage unbalance
- Neutral voltage unbalance
- Phase current unbalance
- Neutral current unbalance

The configuration of the bank, the availability of CTs and PTs, the desired level of sensitivity and security are among the factors that determine the appropriate unbalance method to use. Methods use measured quantities, such as bus or neutral voltages and bank or neutral currents, to create an unbalance phasor with magnitude that indicates the number of faulty units.

A. Neutral Voltage Unbalance Protection

For a single- or double-wye capacitor bank with a neutral potential transformer (PT), the neutral voltage unbalance protection method is applied, as shown in Fig. 3. The faulty

element or unit can be in any of the three locations (i.e., three phases) for this configuration.

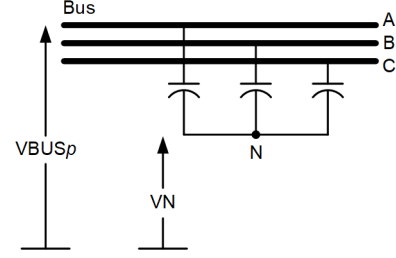

Fig. 3. Ungrounded single-wye bank using neutral voltage unbalance protection.

With the measured voltages from neutral and bus PTs, the neutral unbalance voltage for an ungrounded wye is calculated, as shown in (1).

$$DVG = VBUSA + VBUSB + VBUSC - 3 \cdot VN - [K1 \cdot (VBUSB - VN) + K2 \cdot (VBUSC - VN)] \quad (1)$$

where:

$VBUSp$ is the phase p bus voltage phasor.

VN is the neutral voltage phasor.

$K1$ and $K2$ are settings based on measurements to reset DVG .

B. Neutral Current Unbalance Protection

For a double-wye ungrounded capacitor bank with a CT in the common neutral, neutral current unbalance protection is applied, as shown in Fig. 4. The faulty element or unit can be in any of the six locations (three phases in the left or right sections) for this configuration.

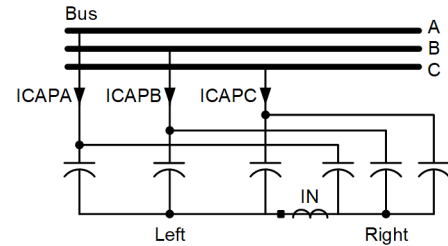

Fig. 4. Double-wye bank using neutral current unbalance protection.

With the measured neutral and bank currents, the neutral unbalance current for an ungrounded double wye is calculated, as shown in (2).

$$60N = IN - (K1 \cdot ICAPB + K2 \cdot ICAPC) \quad (2)$$

where:

$ICAPp$ is the Phase p bank current phasor.

IN is the neutral current phasor.

$K1$ and $K2$ are the scale factor settings based on the relay measurements that reset $60N$.

Capacitor bank unbalance protective relays often provide a manual command to reset the inherent unbalance (update $K1$ and $K2$ factors) to improve sensitivity and security. The inherent unbalance can be from the variation on capacitor units

within manufacturing tolerances, temperature changes, aging effects, etc.

To improve the reliability of unbalance protection, multiple unbalance protection methods can be applied, depending on the bank configuration and availability of instrument transformers. For example, if a neutral PT is available for the double-wye bank shown in Fig. 4, then neutral voltage unbalance protection can be applied along with the neutral current unbalance protection.

This paper focuses only on neutral voltage and neutral current unbalance methods, so phase voltage and phase current unbalance methods are not discussed.

IV. SINGLE-PHASE FAULT LOCATION IDENTIFICATION (EXISTING SOLUTION)

Faulted phase and section identification methods are already developed into products and are being used for single-phase faults in single- or double-wye arranged banks [2] [5] [6].

The method presented in [2] measures the unbalance phasor quantity and uses the resulting phase magnitude for unbalance protection and the phase angles for fault location. The phase angle of the unbalance quantity is compared with a reference quantity phase angle. The reference quantity can be from the following:

- Phase voltage (bus)
- Phase current (bank)
- Positive-sequence bus voltage
- Positive-sequence bank current

If the bank is protected with the neutral voltage or neutral current unbalance protection method, then positive-sequence bus voltage or positive-sequence bank current can be used as the reference quantity. The referenced unbalance angle is then checked to see if it falls in a specific angular sector. Each angular sector indicates a specific fault location (A-, B-, or C-phases and left or right sections). For example, if a double-wye fuseless SCB develops a fault in a unit or element in the A-phase of the left bank, that results in unbalance current to flow in the neutral. This unbalance current is in phase (or 180 degrees out of phase, according to the polarity of the neutral CT) with reference to positive-sequence bank current. If the fault is in the A-phase of the right bank, then the unbalance current is 180 degrees out of phase. If the fault is in the B-phase of the left bank, then the phase lags by 120 degrees, and if it is in B-phase of the right bank, then the phase leads by 60 degrees (similar to a fault in the C-phase left or right section of the bank). Basically, six faults in a double-wye bank with a neutral CT results in unbalance current having six unique angles in reference to the positive-sequence bank current. Using this unique phase relationship, we can locate the phase and section that has the faulty unit or element.

For security, a ± 15 -degree blinder is applied to account for instrument transformer errors, inherent unbalance due to temperature changes, etc. This 15-degree security blinder results in six fault location sectors, each separated by 60 degrees. The fault location technique is supervised by an unbalance alarm or trip for sensitivity. The fault location technique is affected by the fusing method. For fused banks,

impedance increases after a fuse operation, but for fuseless banks, impedance decreases. This impedance variation results in unbalance current in fused banks to be 180 degrees out of phase compared to fuseless banks, so the fault location sector for fused banks should be 180 degrees out of phase compared to a fuseless bank fault sector. The fault location technique relies on unbalance protection to compensate for inherent unbalance within the bank. The fault location information can be included as part of the event report and can be used by the utility crew to perform planned maintenance. If a fault happens in one phase (or section) followed by another fault in different phase (or section) before resetting the unbalance alarm, then the fault location is compromised. This means the referenced unbalance angle falls in an undefined sector, preventing fault location. This limitation becomes the motivation for introducing the multiphase, multisection SCB fault location method.

V. MULTIPHASE, MULTISECTION FAULT LOCATION: (PROPOSED SOLUTION)

The multiphase, multisection fault location solution is an improvement to the existing single-phase, single-section fault location solution covered in the previous section. It defines additional angle sectors that can be used to detect multiphase faults for single- or double-wye ungrounded banks and multiphase, multisection faults for double-wye ungrounded banks.

The proposed solution addresses the following:

- Identify the faulted phases (AB, BC, or CA) and sections (left or right) for multiphase, multisection faults in two different sections of the ungrounded double-wye configuration (e.g., left-side A-phase and right-side C-phase).
- Identify the faulted phases (AB, BC, or CA) for multiphase faults in the left section of ungrounded double-wye configurations (e.g., left-side B-phase and left-side C-phase).
- Identify the faulted phases (AB, BC, or CA) for multiphase faults in the right section of ungrounded double-wye configurations (e.g., right-side B-phase and right-side C-phase).

Since the fault location solution does not need a separate device or require additional equipment beyond the standard protection, the improved fault location solution is cost-free.

Fig. 5 shows 12 equally spaced-out 30-degree angular sectors. The additional six sectors (compared to single-phase fault location) come from the multiphase (AB, BC, or CA) multisection (left or right) faults. The referenced unbalance phasor angles (Φ) ($60N_{\text{ang}}$ and DVG_{ang}) are checked to see if they fall in any of those 12 angular sectors. For sensitivity, the angle check is enabled when unbalance within the bank results in an alarm or trip.

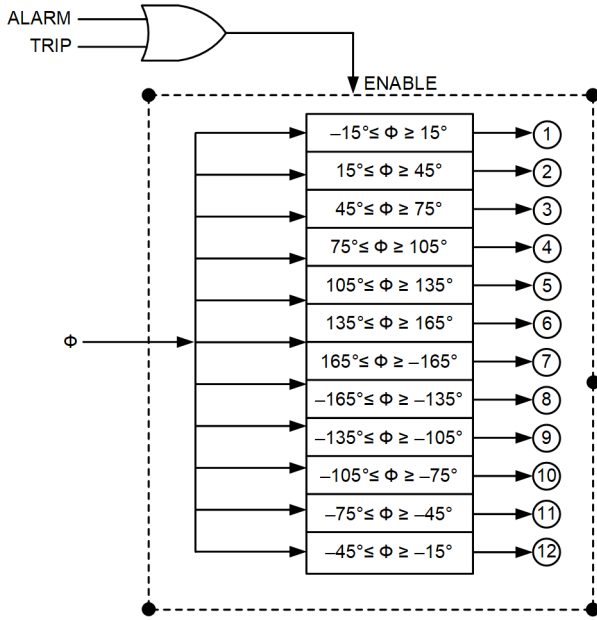

Fig. 5. Multiphase, multisection fault location sectors.

There is an ambiguity to detect multiphase faults in the same section of an ungrounded double-wye bank. The $60N_{ang}$ for a multiphase fault in the B-phase and C-phase of the left section is in the same fault location angular sector as a single-phase fault in the A-phase of the left section (similar to the multiphase faults AB and CA); DVG_{ang} for a multiphase fault is in a different angular sector compared to single-phase fault. Similar ambiguity exists for multiphase faults in the right section of an ungrounded double-wye bank. There is no ambiguity for multiphase, multisection faults in a double-wye ungrounded bank.

If the bank is fused, then Φ in Fig. 5 is 180 degrees out of phase compared to a fuseless bank, so Sector 1 in a fused bank becomes Sector 7 in a fuseless bank, and similarly, Sector 2 in a fused bank becomes Sector 8 in a fuseless bank.

A. Multiphase, Multisection Faults Occur on Both the Left and Right Sides of the Ungrounded Double-Wye Bank

To detect and identify multiphase, multisection faults in a double-wye ungrounded bank, a neutral CT with neutral current unbalance protection is sufficient.

Fig. 6 shows the fault location technique for multiphase, multisection faults in ungrounded double-wye banks that use neutral current unbalance protection. If $60N_{ang}$ is in Sectors 2, 4, 6, 8, 10, or 12, then the fault is multiphase and multisection, as it occurs on both the left and the right sections of the double wye.

From Fig. 6, LBRA indicates a multiphase, multisection (left-side B-phase and right-side A-phase) fault occurring in the ungrounded double-wye bank. LBRA is asserted when $60N_{ang}$ is in Sector 2 of Fig. 5, indicating a 30-degree deviation from the reference. Similarly, LBRC indicates a fault in the left-side B-phase and right-side C-phase, etc.

Switch at the position a if the bank is fuseless
Switch at the position b if the bank is fused

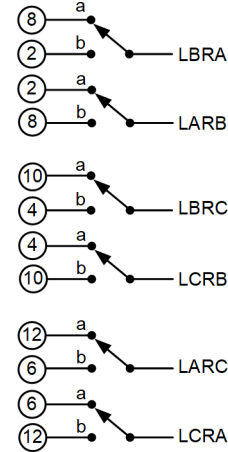

Fig. 6. Multiphase, multisection fault location for ungrounded double-wye banks that use neutral current unbalance protection.

B. Multiphase Faults Occur on the Left Side of the Ungrounded Double-Wye Bank

To detect and identify a multiphase fault on the left side of a double-wye ungrounded bank, a neutral CT with neutral current unbalance protection and a neutral PT with neutral voltage unbalance protection are needed.

Fig. 7 shows the fault location technique for multiphase faults on the left side of ungrounded double-wye banks that use neutral current and neutral voltage unbalance protection. If $60N_{ang}$ and DVG_{ang} are in Sectors 1, 5, or 9, then the fault is multiphase and in the left section.

From Fig. 7, LEFTAB indicates a multiphase (A-phase and B-phase) fault occurring on the left side of the ungrounded double-wye bank. For a fused bank, LEFTAB is asserted when $60N_{ang}$ and DVG_{ang} are in Sector 5 (or Subscript 5) of Fig. 5, indicating a 120-degree deviation from the reference. Similarly, LEFTBC indicates a fault in the B-phase and C-phase on the left side, etc.

Switch at the position a if the bank is fuseless
Switch at the position b if the bank is fused

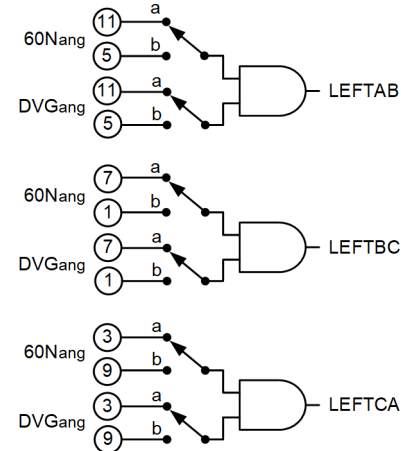

Fig. 7. Left-side multiphase fault location for ungrounded double-wye banks that use neutral current and neutral voltage unbalance protection.

D. Multiphase Faults Occur on the Right Side of the Ungrounded Double-Wye Bank

To detect and identify a multiphase fault on the right side of a double-wye ungrounded bank, a neutral CT with neutral current unbalance protection and a neutral PT with neutral voltage unbalance protection are needed.

Fig. 8 shows the fault location technique for multiphase faults on the right side of ungrounded double-wye banks that use neutral current and neutral voltage unbalance protection. If $60N_{ang}$ and DVG_{ang} are in Sectors 11 and 5, 7 and 1, or 3 and 9, then the fault is multiphase and in the right section.

From Fig. 8, RIGHTAB indicates a multiphase (A-phase and B-phase) fault occurring on the right side of the ungrounded double-wye bank. For a fused bank, RIGHTAB is asserted when $60N_{ang}$ is in Sector 11 (indicating a 60-degree deviation) and DVG_{ang} is in Sector 5 (indicating a 120-degree deviation). Similarly, RIGHTBC indicates a fault in the B-phase and C-phase on the right side, etc.

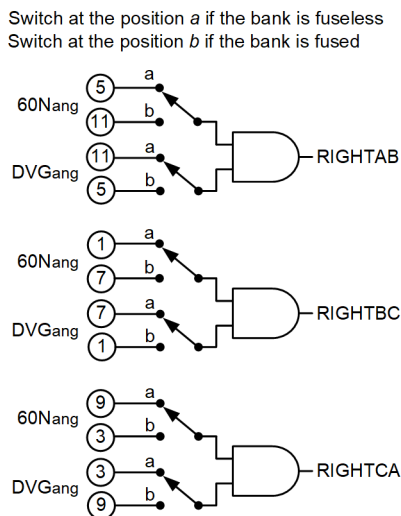

Fig. 8. Multiphase fault location on the right side of the double-wye.

With the availability of both neutral current and neutral voltage unbalance protection, the proposed fault location solution can detect and identify all three multiphase and multisection faults in an ungrounded double-wye bank.

VI. SIMULATION SETUP AND RESULTS

To validate the fault location technique for various capacitor bank configurations, the power system shown in Fig. 9 is modeled using a real-time digital simulator (RTDS).

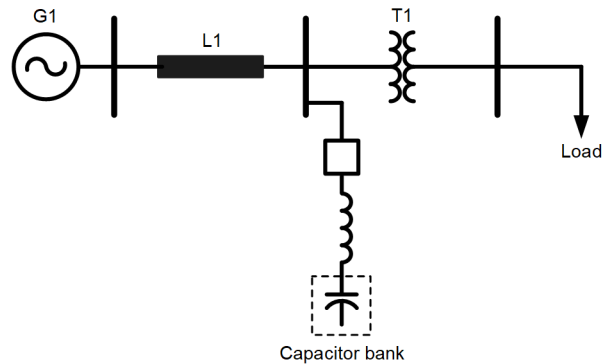

Fig. 9. Power system modeled in RTDS.

The capacitor bank is rated at 33 kV, 50 MVAR. The bank is a double-wye ungrounded configuration and has a neutral CT for neutral current unbalance protection and a neutral PT for neutral voltage unbalance protection. The bank consists of 18 single-phase internally fused capacitor units. Fig. 10 shows the representation of the bank. There are 15 elements connected in parallel to form a series group, and 5 elements make a capacitor unit. The capacitor unit is rated at 10.987 kV and 705 kVAR.

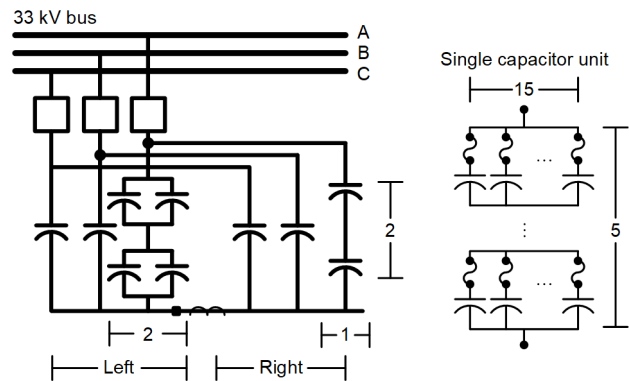

Fig. 10. Capacitor bank model for neutral voltage and neutral current unbalance fault location.

The proposed multiphase, multisection fault location including the unbalance protection is modeled in RTDS, and the performance is evaluated by simulating fuse failures in multiphases and multisections of the double-wye bank.

A. Multiphase, Multisection Faults Occur Both on the Left and Right Sides of the Ungrounded Double-Wye Bank

Fig. 11 shows the bank and neutral currents measured by the bank and neutral CTs. They are inputs for a relay model that provides the unbalance protection. Fig. 11 also shows the neutral current unbalance magnitude and referenced neutral current unbalance angle from the relay model.

An internal fault is simulated by shorting elements in the B-phase of the left side and A-phase of the right side. The fault is cleared by the fuses for the shorted elements, resulting in an unbalance current magnitude of 0.154 A secondary with an unbalance angle of 35.25 degrees. Fig. 11 shows the logic correctly asserting 60ALARM and LBRA, indicating the faulty units are in the B-phase of the left side and A-phase of the right side.

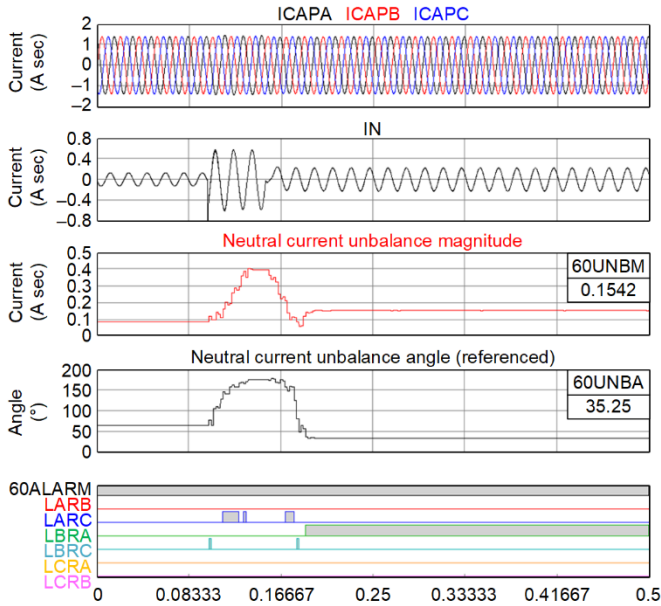

Fig. 11. Multiphase, multisection fault in the B-phase left section and A-phase right section of the ungrounded double wye that is using neutral current unbalance protection.

The remaining cases in Fig. 6 are simulated and have similar results, but only one case is presented in this paper.

B. Multiphase Faults Occur on the Left Side of the Ungrounded Double-Wye Bank

Fig. 12 shows the bank and neutral currents measured by the bank and neutral CTs. Fig. 12 also shows the neutral current unbalance magnitude, referenced neutral current, and voltage unbalance angle from the relay model.

An internal fault is simulated by shorting elements in the A-phase and B-phase of the left side. The fault is cleared by the fuses for the shorted elements, resulting in an unbalance current magnitude of 0.090 A secondary with an unbalance current angle of 125.30 degrees and unbalance voltage magnitude of 0.370 V secondary with an unbalance voltage angle of 121.20 degrees.

Fig. 12 shows the logic correctly asserts 60ALARM, DVGALARM, and LEFTAB, indicating the faulty units are in the A-phase and B-phase of the left side.

The remaining cases in Fig. 7 are simulated and have similar results, but only one case is presented in this paper.

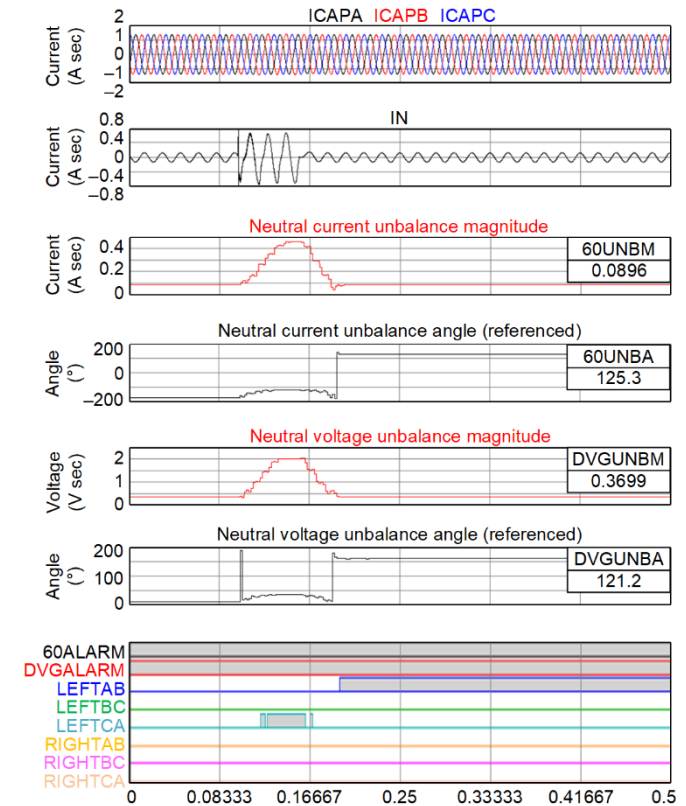

Fig. 12. Multiphase fault in the A-phase and B-phase on the left side of the ungrounded double-wye bank that is using neutral current and neutral voltage unbalance protection.

C. Multiphase Faults Occur on the Right Side of the Ungrounded Double-Wye Bank

An internal fault is simulated by shorting elements in the A-phase and B-phase of the right side. The fault is cleared by the fuses for the shorted elements, resulting in an unbalance current magnitude of 0.090 A secondary with an unbalance current angle of -54.77 degrees and unbalance voltage magnitude of 0.370 V secondary with an unbalance voltage angle of 121.30 degrees.

Fig. 13 shows the logic correctly asserts 60ALARM, DVGALARM, and RIGHTAB, indicating the faulty element or units are in the A-phase and B-phase of the right side.

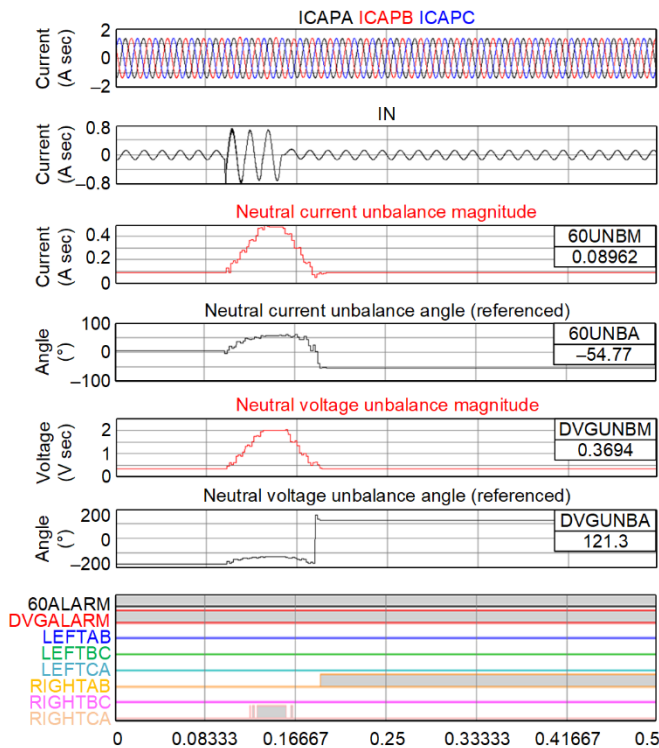

Fig. 13. Multiphase fault in the A-phase and B-phase on the right side of the ungrounded double-wye bank that is using neutral current and neutral voltage unbalance protection.

The remaining cases in Fig. 8 are simulated and have similar results, but only one case is presented in this paper.

VII. CONCLUSION

Identifying faulty units in internally fused or fuseless SCBs can be time-consuming and can result in the unavailability of critical VAR support when needed.

The proposed multiphase, multisection fault location solution is an extension of the single-phase fault location technique, and it expands the capabilities of the existing technique by identifying faults on more than one phase. With the proposed solution in this paper, two phases of a single-wye ungrounded shunt capacitor bank or two phases in two different sections (left and right) of the double-wye bank can be identified. The solution is economical, as it does not require any additional equipment, such as CTs and PTs. The solution can be easily integrated in the relay with programming capability. The fault location information can be used by the utility crew to expedite the maintenance.

VIII. REFERENCES

- [1] R. Natarajan, *Power System Capacitors*. CRC Press, Boca Raton, FL, 2005.
- [2] J. Schaefer, S. Samineni, C. Labuschagne, S. Chase, and D. J. Hawaz, "Minimizing Capacitor Bank Outage Time Through Fault Location," proceedings of the 67th Annual Conference for Protective Relay Engineers, College Station, TX, March 2014.
- [3] B. Kasztenny, J. Schaefer, and E. Clark, "Fundamentals of Adaptive Protection of Large Capacitor Banks," proceedings of the 60th Annual Georgia Tech Protective Relaying Conference, Atlanta, GA, May 2006.
- [4] IEEE Standard C37.99-2012, *IEEE Guide for the Protection of Shunt Capacitor Banks*.

- [5] S. Samineni, C. Labuschagne, and J. Pope, "Principles of Shunt Capacitor Bank Application and Protection," proceedings of the 36th Annual Western Protective Relay Conference, Spokane, WA, October 2009.
- [6] S. Samineni and C. Labuschagne, "Apparatus and Method for Identifying a Faulted Phase in a Shunt Capacitor Bank," U.S. Patent 8,575,941, November 2013.

IX. BIOGRAPHIES

Dereje Jada Hawaz received his BSEET from DeVry University in 1999, his MEEE from the University of Idaho in 2013, and a PhD in electrical engineering from the University of Idaho in 2021. He joined Schweitzer Engineering Laboratories, Inc. (SEL) in 1999 and has been involved in designing, developing, and validating protective relays. He authored several technical papers and holds a patent related to power system protection. He is currently a senior engineer in the research and development division and is a member of the IEEE.

Satish Samineni received his bachelor of engineering degree in electrical and electronics engineering from Andhra University, Visakhapatnam, India, in 2000. He received his master's degree in electrical engineering in 2003 and a PhD in 2021 from the University of Idaho. Since 2003, he has been with Schweitzer Engineering Laboratories, Inc. (SEL) in Pullman, Washington, where he is a principal research engineer in the research and development division. He has authored or coauthored several technical papers and holds multiple U.S. patents. His research interests include power system protection, power system modeling, power electronics and drives, synchrophasor-based control applications, and power system stability. He is a registered professional engineer in the state of Washington and a senior member of IEEE.

Brian K. Johnson is the Schweitzer Engineering Endowed Chair in Power Engineering and University Distinguished Professor in the Department of Electrical and Computer Engineering at University of Idaho. He received a PhD degree in electrical engineering from the University of Wisconsin-Madison. His teaching and research interests include power system protection, integration of inverter-based generation, HVDC transmission, FACTS devices, power systems transients, and power system resilient control. Dr. Johnson is a professional engineer in the state of Idaho.