

# Securing Line Current Differential on Multiplexed Communication Channels

Craig Wester, Mike Ramlachan – GE Vernova  
Jamie Segarra – Orlando Utilities Commission

## Abstract

The application of current differential protection (87L) on transmission lines over direct fiber communications has proven to be reliable for electric utilities, providing the correct balance of dependability (operate correctly when needed) and security (avoid unnecessary operation). However, the application of line current differential protection over multiplexed communication channels introduces challenges to the protection engineer. Occasionally, multiplexed communications channels can experience issues during switching or network issues that can cause extensive channel delays and channel asymmetry. Extensive channel delays can cause delayed protective relay tripping reducing dependability of the system. Asymmetry occurs when the send/transmit and receive paths are not equal (i.e., not symmetrical). Channel asymmetry gives higher angular difference between local and remote currents and therefore higher differential current which can cause the 87L element to operate and sacrificing security of the protection system. This paper will review the above mentioned challenges and discuss several methods of securing line differential protection on multiplexed communication channels.

## Introduction

For two terminal applications, transmission line current differential relaying (87L) measures and compares the currents at both ends of the transmission line using two separate relays and a communications channel. 87L protection compares the phase currents ( $I_a$ ,  $I_b$  and  $I_c$ ) magnitudes and phase angles from each end of the transmission line using a communication channel such as single-mode direct fiber or multiplexed fiber. The advantages of 87L protection are the distinct zones of protection since 87L will cover the complete transmission line without overreaching, high speed detection within 2 cycles, and immunity to power swings. Modern relays with 87L protective element can include complete backup distance protection with or without pilot-aided schemes. An example 87L two terminal transmission line application is shown in Figure 1.

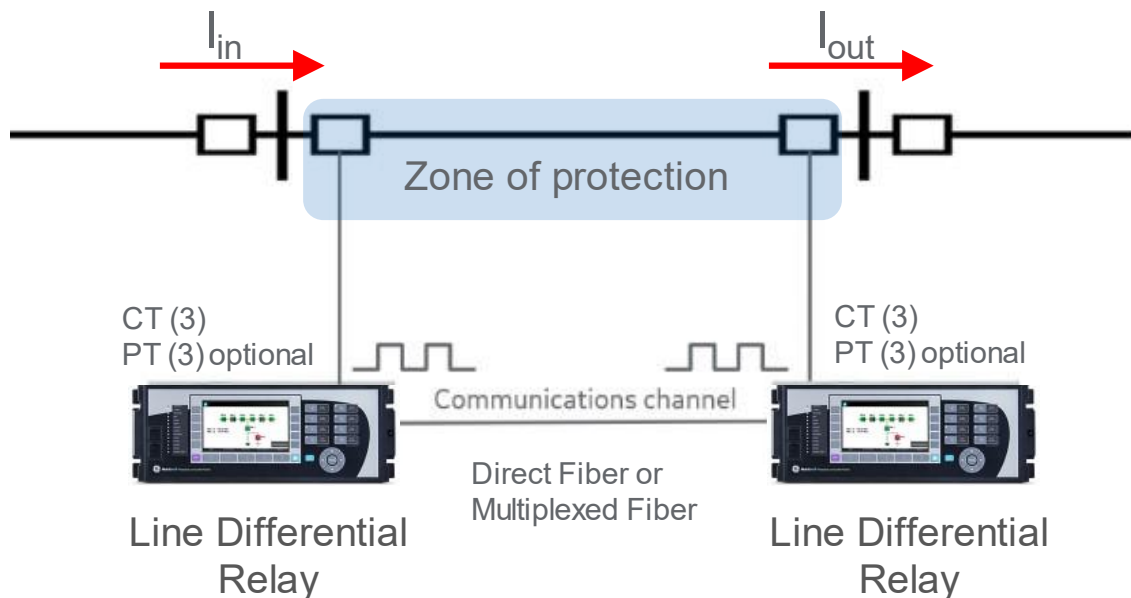

Figure 1 – Two Terminal 87L Transmission Line Protection

As shown in Figure 2, two-terminal line-current differential relaying operates as follows:

- Upon powering up, the two 87L relays synchronize their internal clocks via the communications channel.
- Each 87L relay measures the currents at its CT and sends this information, along with a time stamp, to the remote 87L relay.
- Using a percent differential element, each 87L relay compares the time-stamped current measured at its location with the time-stamped current received from the remote 87L relay on a per-phase basis. The differential current is the magnitude of the vector summation of the local and remote phase currents and is approximately equal zero during no fault conditions (i.e., the same current entering and leaving the line).
- If there is a fault on the transmission line between the two terminals (in zone fault), the current entering and leaving the line will be different, the measured per-phase differential current ( $I_d$ ) of each 87L relay will be above the 87L pickup setting and both 87L relays will operate to isolate that section of line from the rest of the power system.
- Each 87L relay can send a direct transfer trip signal to the remote 87L relay via the communications channel if it calculates a differential current (i.e., the difference in the vector summation of the local and remote phase currents) that is above the  $I_d/I_r$  slope characteristic.

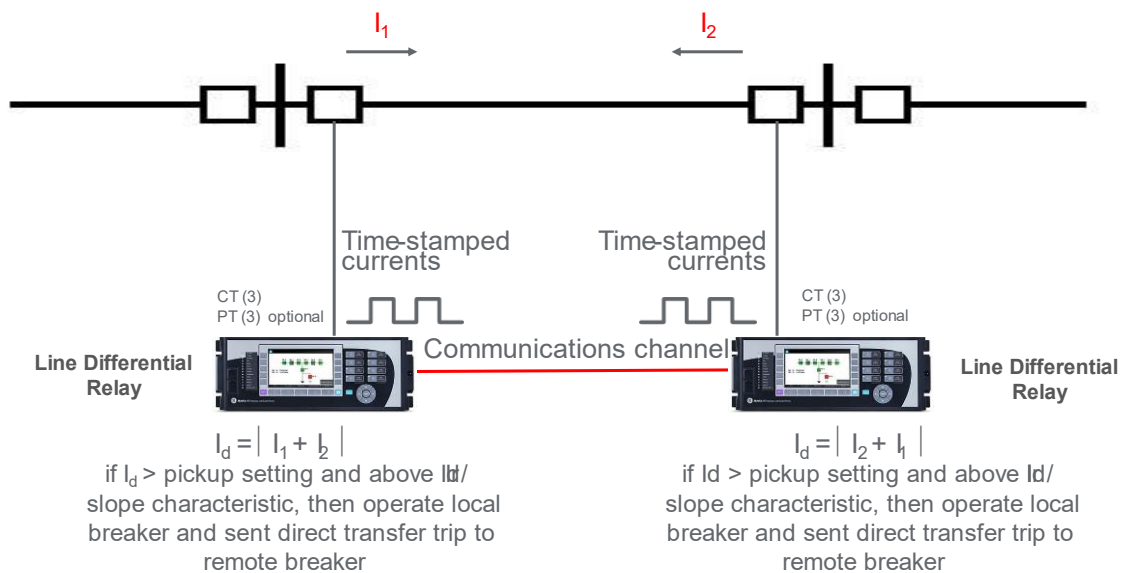

Figure 2 – Two Terminal 87L Line Protection Operation

### Challenges for Line Differential Protection Using Multiplexed Fiber Communications Channels

Multiplexed fiber communication channels may experience communication issues during switching or network issues that can cause extensive channel delays and extensive channel asymmetry to the 87L line differential protection scheme. From a protection engineer perspective, an inconsistent communication channel for line differential protection is unacceptable.

- A typical round trip channel delay is 8 to 16 ms for a multiplexed fiber communication channel. An extensive communication channel delay can cause delayed protective relay tripping of the 87L line differential protection. Thus, the operating time of the 87L differential element will be delayed by the excessive channel delay.
- Channel asymmetry occurs when the send/transmit and receive paths are not equal (i.e., not symmetrical) for a multiplexed fiber communication channel. Typical channel asymmetry is less than 3 to 4ms for a multiplexed fiber communication channel. 87L line differential protection relays do have the capability to automatically compensate for

channel asymmetry. Excessive channel asymmetry can give higher angular difference between local and remote currents of the 87L line differential protection and result in higher differential currents which can cause 87L element to operate. An example is shown in Figure 3 where a multiplexer equipment issue resulted in excessive channel asymmetry to both 87L line differential relays which created 87L differential current on phase A, B and C above the 87L differential element pickup. Figure 4 shows that the local and remote currents were equal in magnitude, however there was a high angle difference between the local and remote currents due to the excessive channel asymmetry of the multiplexed communication channel. This excessive channel asymmetry caused differential currents over the 87L differential pickup setting.

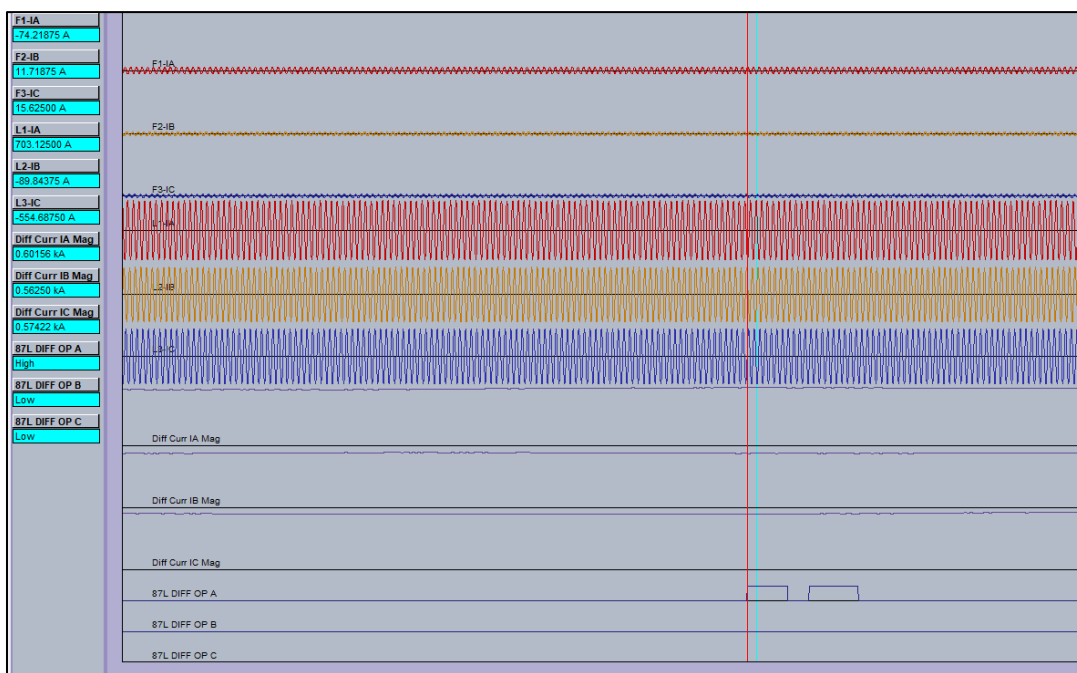

Figure 3 – 87L Line Protection Operation Due to Excessive Channel Asymmetry

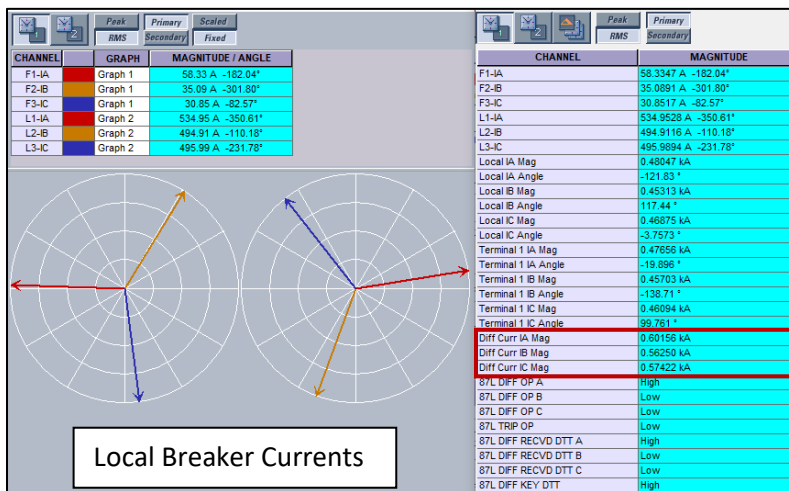

Figure 4 – Excessive Channel Asymmetry Example

## Methods of Securing Line Differential Protection Using Multiplexed Communication Channels

There are several methods available in modern protective relays to secure 87L line differential protection with communications through fiber multiplexed channels.

### Method 1:

One method is to use channel asymmetry compensation within the 87L line relay. Channel asymmetry compensation is based on absolute time referencing provided by a high precision system such as a global positioning system (GPS) receiver via precision time protocol (PTP) or IRIG-B. It is recommended to use this functionality on multiplexed channels where channel asymmetry can be expected and result in higher differential currents. Depending on the manufacturer of the 87L line relay, there will be a maximum asymmetrical channel delay compensation that can be provided using an absolute time reference. The 87L element could be blocked if the maximum asymmetrical channel delay goes over a set value. The most common and readily available absolute time reference is the afore mentioned time signal provided by GPS (United States) and until recently GLONASS (Russian). Most modern receivers today support GNSS, combination of GPS and GLONASS. The time signal reference for this paper and examples are provided by a GPS receiver and will only be referred to from now. The channel asymmetry compensation functionality will take effect when all terminals are provided with reliable GPS clock signals. If the GPS clock signal is lost at any terminal of the current differential protection system, or the real time clock is not configured, then the compensation cannot be calculated. If the compensation is in place prior to losing the GPS time reference, the last (memorized) correction will be applied. Channel asymmetry can also be monitored with metering values and an indication or alarm given when the maximum channel asymmetry is above a user programmable setpoint. Depending on the implemented relaying philosophy, the 87L line differential relays could be programmed to perform the following on the loss of the GPS signal:

- A. **Enable GPS channel compensation and continue to operate the 87L differential element until a change in the channel round-trip delay is detected during a loss of GPS signal.** If GPS is enabled and present at all terminals, the 87L line relays will compensate for the channel asymmetry. On the loss of the GPS signal, the 87L line relays will store the last measured value of the channel asymmetry per channel and compensate for the asymmetry until the GPS clock is available. However, if the channel was switched to another physical path during GPS loss conditions, the 87L differential element must be blocked, since the channel asymmetry cannot be measured and 87L line differential function is no longer accurately synchronized. The value of the step change in the channel can be measured by the 87L line relay and a setpoint can be configured for the channel round trip time change (typically 1.5ms). It is recommended to configure round trip time change detector/alarm to 20% more than the in-service metering value of channel loop delay. This method can be implemented using the following steps:
  1. Enable channel asymmetry compensation in 87L line relay and assign the GPS receiver failsafe alarm contact (indicating GPS receiver problems or time inaccuracy) to block GPS channel compensation. Some GPS receivers supply erroneous IRIG-B signals during power-up and before locking to satellites. If the GPS receiver's failsafe contact opens during power-up (allowing for an erroneous IRIG-B signal), then it is recommended to configure a dropout delay up to 15 minutes (depending on GPS receiver specifications) to the failsafe contact via logic to prevent any issues.
  2. Use logic shown below in Figure 5 to block the 87L differential element on GPS loss if step change in the channel delay occurs during GPS loss conditions or on a startup before the GPS signal is valid. The Block 87L output is reset if the GPS signal is restored and the 87L element is ready to operate.

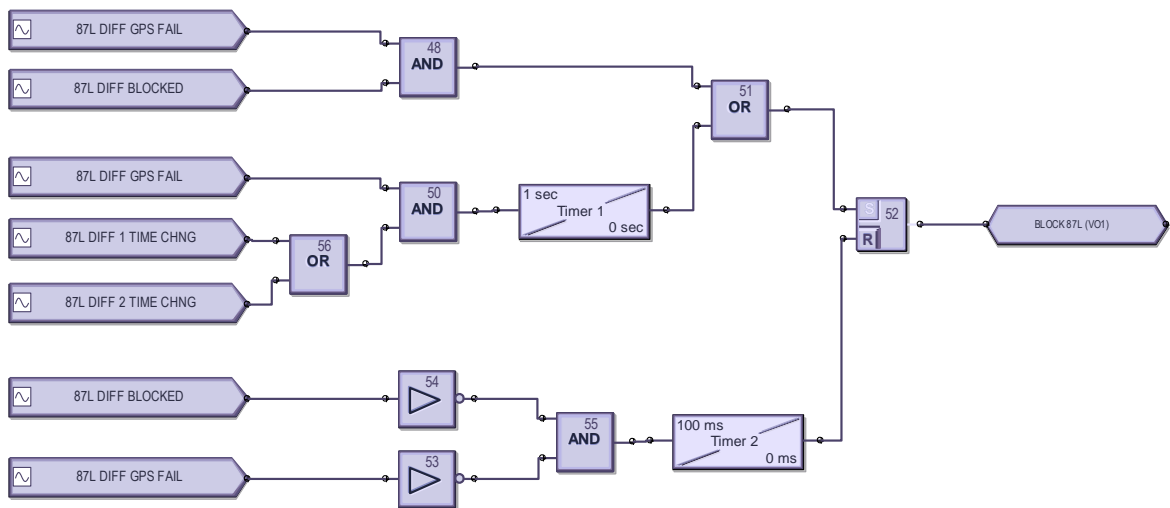

Figure 5 – Block 87L Logic for GPS Failure and Channel Step Change

B. **Enable GPS channel asymmetry compensation and for the loss of the GPS signal at any terminal block the 87L differential element after a specified time.** This is a simple and conservative way of using the GPS channel asymmetry compensation feature. This method can be implemented using the following steps:

1. Enable channel asymmetry compensation in 87L line relays and assign the GPS receiver failsafe alarm contact (indicating GPS receiver problems or time inaccuracy) to block GPS channel compensation. Some GPS receivers supply erroneous IRIG-B signals during power-up and before locking to satellites. If the GPS receiver’s failsafe contact opens during power-up (allowing for an erroneous IRIG-B signal), then it is recommended to configure a dropout delay up to 15 minutes (depending on GPS receiver specifications) to the failsafe contact via logic to prevent any issues.
2. Use the logic shown below in Figure 6. It is recommended that the timer be set no higher than 10 seconds.

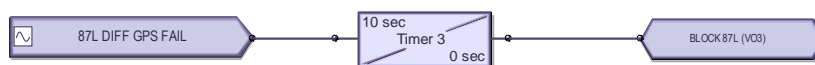

Figure 6 – Block 87L Logic for GPS Failure for Specified Time

C. **Continuously operate the 87L differential element but enable GPS channel asymmetry compensation only when valid GPS signals are available.** This provides less sensitive protection on GPS signal loss at any terminal and requires higher 87L pickup and restraint settings. This approach can be used carefully if maximum channel asymmetry is known and does not exceed certain values (typically 2 to 3 ms). It is recommended to configure maximum channel asymmetry detector/alarm to 20% more than the in-service metering value of channel asymmetry. The 87L differential maximum channel asymmetry alarm and can be used to monitor and signal maximum channel asymmetry. Essentially, the 87L line relay switches to another setting group with higher 87L pickup and restraint settings for a GPS signal loss, sacrificing sensitivity to keep the 87L function operational. This method can be implemented using the following steps:

1. Use logic shown below in Figure 7 to switch the 87L element to settings group 2 (with most sensitive settings) if the 87L line relay has a valid GPS time reference. If a GPS or 87L communications failure occurs, the 87L line relay switches back to Settings Group 1 with less sensitive settings.

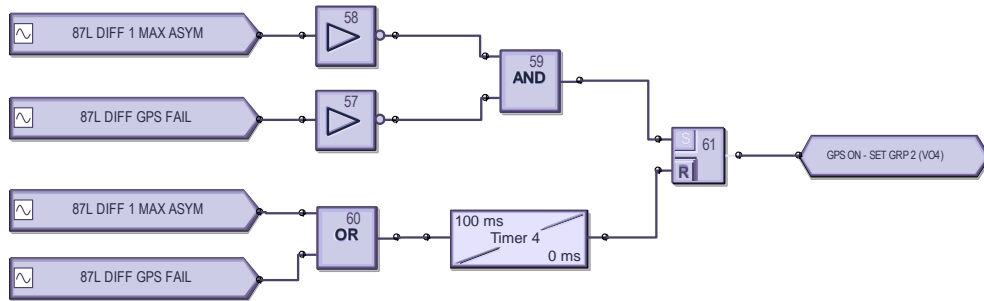

Figure 7 – Switching 87L Setting for GPS Failure

2. Configure the 87L element with different differential settings for settings groups 1 and 2.
  - a. Settings group 1 – 87L differential settings would be less sensitive (i.e., higher 87L pickup and restraint settings)
  - b. Settings group 2 – 87L differential settings would be the normal 87L pickup and restraint settings

Settings Group 1

Pickup	0.50 pu
CT Tap 1	1.00
Restraint 1	40 %
Restraint 2	70 %
Breakpoint	2.0 pu

Settings Group 2

Pickup	0.20 pu
CT Tap 1	1.00
Restraint 1	25 %
Restraint 2	45 %
Breakpoint	2.0 pu

3. Enable GPS channel asymmetry compensation when the GPS signal is valid and switch to settings group 2 with normal 87L pickup and restraint settings.

Method 2:

Another method to secure 87L line differential protection with communications through fiber multiplexed channels is by adding additional security to the 87L differential element by supervision with a high speed disturbance detector (50DD). This disturbance detector (50DD) element is a sensitive current disturbance detector that is used to detect any disturbance (or possible fault) on the protected system. Method 2 uses Method 1 plus the addition security shown in Figure 8.

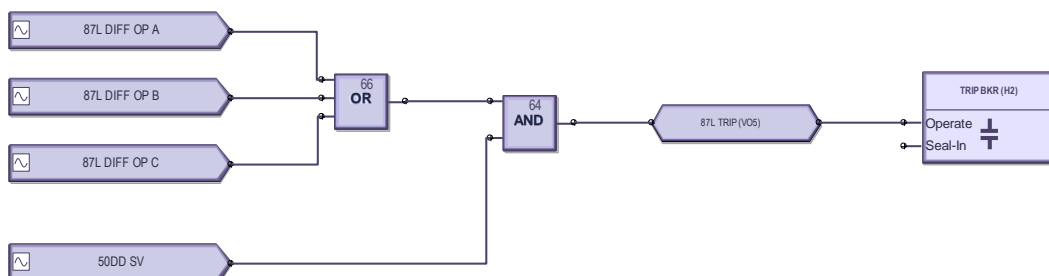

Figure 8 – Supervising 87L Operation with Disturbance Detector

## Additional Items for Consideration

It is valuable when troubleshooting communication channel issues to have information from the 87L line relay regarding channel round trip channel delay, channel loop delay and channel asymmetry. Values of channel round trip channel delay, channel loop delay and channel asymmetry are metered values provided by the 87L line relay. In addition, it is recommended to configure a datalogging function in the 87L line relay to record the channel asymmetry value over a period of time (every hour or day) and review the data captured when issues arise.

To alert the user of a possible issue, one could alarm to SCADA system when the following occur:

- 87L differential element blocked
- Excessive channel round trip time change
- Excessive channel asymmetry
- GPS failure

## Conclusions

87L line current differential protection over multiplexed communication channels introduces challenges to the protection engineer. Multiplexed communications channels can experience issues during switching or network issues which can cause extensive channel delays and channel asymmetry. These extensive channel delays may cause delayed protective relay tripping. Asymmetry occurs when the send/transmit and receive paths are not equal (not symmetrical). Channel asymmetry produces higher angular difference between local and remote currents and therefore higher differential current which can cause operation of 87L differential element. There are several methods of securing line differential protection on multiplexed communication channels, such as GPS channel asymmetry compensation and supervising 87L differential operation with a high-speed disturbance detector. Various methods were discussed regarding handling a loss of GPS signal to 87L line relay. Valuable channel information (channel asymmetry, channel round trip delay, channel loop delay) can be metered and recorded by the 87L line relay for troubleshooting purposes. SCADA alarms such as 87L differential element blocked, excessive channel round trip time change, excessive channel asymmetry and GPS failure are beneficial.

## Biographies

**Craig Wester** is a Senior Technical Application Engineer for the protection and control division of GE Vernova for the South Region of North America. He was previously a Senior Regional Sales Manager for the south region of GE in North America for protection and control. He joined GE in 1989 as a Transmission & Distribution Application Engineer. He received his Bachelor of Science in electrical engineering from University of Wisconsin-Madison. He is a senior member of IEEE.

**Ravindranauth Ramlachan (Mike)** is Application Team Leader for the protection and control division of GE Vernova for the South Region in North America. He was previously a Lead Sales Application Engineer at GE in North America for protection and control. Prior to joining Alstom/GE in 2013, he worked at Consolidated Edison of NYC in various P&C positions. He has a Master of Science degree in electrical engineering acquired from Stevens Institute of Technology.

**Jamie Segarra** is a Senior Protection & Control Engineer for Orlando Utilities Commission. Prior to joining Orlando Utilities Commission, he worked at Duke Energy in Lake Mary, FL as a lead protection and control engineer for 15 years. He has a Bachelor of Science degree in electrical engineering from Polytechnic University of Puerto Rico.