

Detecting and Isolating Falling Conductors in Midair—First Field Implementation on Double-Phase Distribution Circuits

Charlie Cerezo, *San Diego Gas & Electric Company*

Tanushri Doshi, Rohit Sharma, Joe Stanley, and David Almendarez, *Schweitzer Engineering Laboratories, Inc.*

Abstract—Downed energized conductors on distribution circuits present a wildfire risk and a public safety hazard. These broken and energized wires may create a high-impedance ground fault, which may be challenging or nearly impossible to detect by traditional system protection at the substation level. A falling conductor protection (FCP) solution, based on IEEE C37.118 Synchrophasor protocol and IEC 61850 Generic Object-Oriented Substation Event (GOOSE) protocol, has been implemented successfully on multiple San Diego Gas & Electric Company (SDG&E) 12 kV three-phase circuits.

The existing FCP solution uses rate-of-change of phase voltage, negative-sequence voltage magnitude and angle, and zero-sequence voltage magnitude and angle methods for detecting a broken conductor on three-phase circuits. Three-phase distribution circuits typically branch out into double-phase and single-phase laterals before they serve end users. In such systems, it becomes challenging to calculate the sequence components accurately. This paper dives deeper into the enhancements made to the existing FCP solution so that it can be applied to double-phase and single-phase circuits to provide secure and reliable detection of broken conductors. This innovative solution was extensively tested and validated in the laboratory environment using a real-time digital simulator (RTDS) with hardware-in-the-loop (HIL) capability. This first-of-its-kind FCP solution was successfully implemented on a 12 kV SDG&E circuit with double-phase laterals. The circuit has been commissioned and in service under monitoring mode since April 2023.

I. INTRODUCTION

Generally, a power distribution system network consists of a three-phase main line starting from the distribution substation, which serves as the backbone of the network. This main line branches out in double-phase or single-phase laterals toward the end of the line. The density of double-phase or single-phase laterals is observed more in rural areas as these areas do not have high loading.

The wide-area communication-based falling conductor protection (FCP) scheme presented in [1] and [2], which discuss the operating principle behind the scheme, uses a voltage measurement for all three phases at the nodes to calculate the sequence component of the voltage and the disturbance in the voltage. By comparing these voltage sequence components between the nodes, a falling conductor condition was detected. The solution presented was developed using three-phase circuits only, so the enhancement was needed in this FCP scheme to implement the solution to the circuits which have a combination of three-, double-, and single-phase laterals. The algorithm needed to be modified so that the computation of the

voltage sequence component can be performed for the double- and single-phase lateral PMUs.

This paper presents the enhancements that were made to the FCP scheme, which can detect a broken conductor on double- and single-phase laterals as well and isolate the affected section of the circuit within milliseconds of the break [1] [2]. As specified in [2], the scheme is communication-based using the IEEE Std C37.118, *IEEE Standard for Synchrophasor Data Transfer for Power Systems*, and the IEC 61850 Generic Object-Oriented Substation Event (GOOSE) protocol. So far, the FCP scheme is commissioned on multiple San Diego Gas & Electric Company (SDG&E) three-phase distribution circuits. All of these circuits are currently in service and in a monitoring mode. This paper focuses on the first-of-its-kind implementation of an FCP scheme on a 12 kV SDG&E three-phase distribution circuit with double-phase laterals. Before commissioning this enhanced FCP scheme on the circuit, the team performed validation testing of the scheme using a real-time digital simulator (RTDS) with a hardware-in-the-loop (HIL) setup. The scheme has been in service and in a monitoring mode since then on this double-phase lateral distribution circuit.

This paper presents the voltage-based FCP detection schemes and the enhanced methodology to detect falling conductors on single-phase and double-phase laterals, the overall testing methodology, and field commissioning experience to successfully implement an FCP scheme on a distribution circuit.

However, there are other methods to detect a broken conductor in a distribution system that uses current or impedance as operation quantities. The current-based method uses the relationship between positive-, negative- and zero-sequence currents along with the line charging current compensation to detect the falling conductor [3]. It uses the ratio of $(I_2 + I_0) / I_1$ as the principle to detect the broken conductor condition. The impedance-based method uses the rate-of-change of calculated impedance at the top of the feeder to detect the broken conductor condition [4]. The method calculates the delta change in the impedance with the previous sample. If this delta impedance is greater than the pickup, then it detects the broken conductor.

II. BRIEF REVIEW OF FCP SCHEME IN THREE-PHASE DISTRIBUTION CIRCUIT

This section provides a summary of the system architecture that is required to implement the FCP scheme on a typical distribution network. It also provides a brief introduction to the five voltage-based methods that are used to detect falling conductors in this synchrophasor-based scheme. Additional technical details on the system architecture and the principle of operation for each method can be found in [1] and [2].

A. System Architecture

The system architecture of the FCP scheme consists of three important components that are briefly described in the following subsections. More details can be found in [2].

1) Intelligent Electronic Devices (IEDs)

IEDs are the phasor measurement units (PMUs) that are capable of supporting the IEEE C37.118 Synchrophasor protocol and IEC 61850 GOOSE protocol for this application. All IEDs participating in the FCP scheme are time-synchronized using a high-accuracy satellite clock. The IEDs in this scheme have two main functions: sending synchrophasor data, including phasor, analog, and digital information, to the central FCP controller located in the substation and receiving control signals to trip breakers or reclosers in case a falling conductor is detected. The FCP functionalities can be added on top of the already existing system protection on these IEDs.

2) Real-Time Automation Controller (RTAC)

An RTAC is located at the substation and is used as the central FCP controller. The RTAC supports the IEEE C37.118 and IEC 61850 protocols as well. The RTAC communicates over the communications network with all IEDs in a distribution circuit that are identified to participate in FCP. The main functions of the RTAC are to process the synchrophasor data from IEDs, evaluate the conditions of the falling conductor, and send control signals to IEDs to trip the breaker or recloser so that the affected section of the circuit is de-energized before the conductor falls on the ground.

The RTAC, serving as the centralized control device, organizes the various synchrophasor inputs into extensible arrangements of switches and zones. This organization permits the FCP scheme to represent as many or as few individual reclosers as necessary. Furthermore, arranging the scheme to represent individual reclosers as switches and constituting them into one or more zones within a discrete circuit allows the system to operate logic for one or more circuits.

3) Communications Network

The FCP scheme is a wide-area communication-based protection scheme. The communications network needs to support high-speed and low-latency architecture for the IEEE C37.118 and IEC 61850 GOOSE protocols. The communications network infrastructure can consist of wireless radios, fiber optics, or private Long-Term Evolution (PLTE) [2]. The RTAC and all the IEDs participating in the FCP scheme need to be on this communications network. It is necessary for the network latencies to be within a certain threshold since FCP is a high-speed protection application. In

addition to this, the communications network needs to be secure and reliable.

B. Voltage-Based Detection Methods

The distribution FCP scheme is based on five voltage-based methods that are used to detect a falling conductor in the circuit. The RTAC evaluates these conditions from the synchrophasor data from all the PMUs on the distribution circuit that are participating in the FCP algorithm. If the RTAC detects the falling conductor event, it issues GOOSE trip signals to specific PMUs to trip the breaker or recloser to de-energize the affected section of the circuit. The five methods are listed as following.

- Rate-of-change of per-phase voltage (dV/dt)
- Negative-sequence voltage magnitude ($V2Mag$)
- Negative-sequence voltage angle ($V2Ang$)
- Zero-sequence voltage magnitude ($V0Mag$)
- Zero-sequence voltage angle ($V0Ang$)

References [1] and [2] provide more details about these methods.

Fig. 1 represents a simplified single-line diagram of a distribution circuit and is used to discuss the application of the five voltage methods in the event of a falling conductor. In Fig. 1, the power flows from left to right and PMU_n ($n = 1, 2, 3$) are IEDs controlling Breaker n ($n = 1, 2, 3$), respectively.

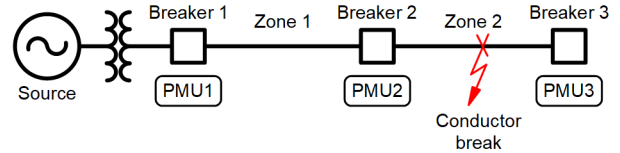

Fig. 1. Example distribution circuit.

Consider a conductor break in one of the three phases between PMU_2 and PMU_3 .

1) Rate-of-Change of Per-Phase Voltage (dV/dt)

During the conductor break, the PMUs on either side of the break experience a rate-of-change of voltage with opposite polarity. For a conductor break in Zone 2 in Fig. 1, PMU_2 and PMU_3 observe a dV/dt spike in opposite polarity. The RTAC detects the falling conductor event in Zone 2 and issues a trip signal to PMU_2 and PMU_3 to isolate and de-energize the affected section of the circuit without affecting the customers in Zone 1. The RTAC supervises the dV/dt method with rate-of-change of zero-sequence voltage ($dV0/dt$) for security against voltage transients that may not be caused by a falling conductor.

2) Negative-Sequence and Zero-Sequence Voltage Magnitudes ($V2Mag$ and $V0Mag$)

The RTAC calculates the negative-sequence and zero-sequence voltage phasors for each PMU based on the synchrophasor data that it receives from that PMU. For a conductor break in Zone 2, the downstream PMU_3 observes a steep increase in $V2Mag$ and $V0Mag$ compared to the upstream PMU_2 , as shown in Fig. 1. The RTAC detects this falling conductor event and issues a trip signal to PMU_2 and PMU_3 to isolate and de-energize the affected section of the circuit before the conductor falls on the ground.

3) Negative-Sequence and Zero-Sequence Voltage Angles ($V2Ang$ and $V0Ang$)

For a conductor break in Zone 2, as shown in Fig. 1, PMU3, which is downstream of the break, aligns its negative-sequence angle and zero-sequence angle in one direction. The PMUs that are upstream of the break, PMU1 and PMU2, align their negative-sequence angle and zero-sequence angle in another direction. If the phase angle difference between these two groups (upstream and downstream) exceeds the set threshold, then a falling conductor is detected by the RTAC. The RTAC detects the falling conductor event and issues a trip signal to PMU2 and PMU3 to isolate and de-energize the affected section of the circuit before the conductor falls on the ground.

The negative-sequence angle and zero-sequence angle methods are supervised by a minimum negative-sequence magnitude and zero-sequence magnitude to authenticate the calculated angle by the RTAC.

The RTAC evaluates the conductor break using these five voltage methods independently. This gives the flexibility to choose and program a voting scheme for tripping. The number of methods that are required to be asserted to issue an FCP trip are user-settable. This helps achieve a balance between sensitivity and security for a given distribution system. The voting scheme may be hard-coded into the RTAC or may be set as a user-settable input controlled via supervisory control and data acquisition (SCADA).

III. FCP SCHEME FOR DOUBLE- AND SINGLE-PHASE DISTRIBUTION CIRCUIT

This wide-area distribution FCP scheme has so far been implemented on multiple 12 kV three-phase distribution circuits. The PMUs on these circuits have voltage measurements available for Phase A, Phase B, and Phase C. Three-phase distribution circuits typically branch out into double-phase and/or single-phase laterals. The existing FCP solution, applicable to three-phase circuits, needed to be modified so that it can be extended to cover the double-phase and single-phase laterals as well. In this section, the authors will describe the challenges and modifications that were made to the existing FCP solution before implementing it on double-phase and single-phase laterals.

A. Problem Statement

Fig. 2 shows a simple distribution circuit, which will be used to demonstrate the challenges encountered when implementing the existing FCP solution on a three-phase circuit with double-phase and single-phase laterals. Fig. 2 consists of three zones: Zone 1 is the three-phase circuit including PMU1, PMU2, and PMU4; Zone 2 shows the double-phase laterals including PMU2 and PMU3; and Zone 3 shows the single-phase lateral including PMU4 and PMU5.

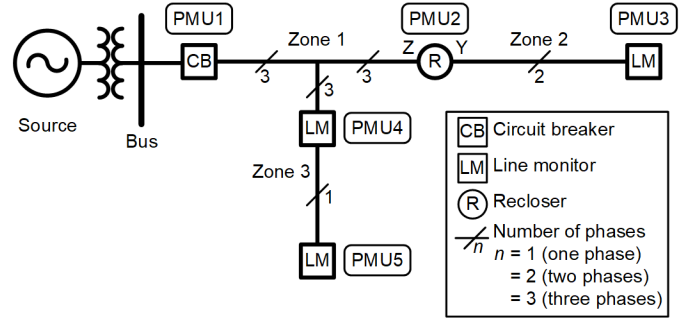

Fig. 2. Typical three-phase distribution circuit with double-phase and single-phase laterals.

To calculate the voltage phasor sequence components, negative-sequence voltage and zero-sequence voltage in this case, all three phase voltages are needed, as per Equation (1). As discussed in Section II, four of the methods to detect the falling conductor are based on the voltage sequence components. Calculating the voltage sequence components for all the participating PMUs in the three-phase circuit is possible. However, the voltage sequence components cannot be calculated if the PMUs are included on the double-phase or single-phase laterals, since one or more phase voltage measurements are not available to the PMU. This challenge limits the existing FCP solution to three-phase circuits. The authors and their extended team members devised an innovative solution so that the existing three-phase FCP solution can be extended to cover double-phase and single-phase laterals as well.

$$\begin{bmatrix} V_0 \\ V_1 \\ V_2 \end{bmatrix} = \frac{1}{3} \begin{bmatrix} 1 & 1 & 1 \\ 1 & \alpha & \alpha^2 \\ 1 & \alpha^2 & \alpha \end{bmatrix} \begin{bmatrix} V_A \\ V_B \\ V_C \end{bmatrix} \quad (1)$$

B. Solution

To implement the existing FCP solution on distribution circuits that may be a combination of three-phase, double-phase, and single-phase laterals, the FCP algorithm in the RTAC was enhanced to make this solution universal.

For a typical radial distribution circuit, the measured voltage drops farther away from the substation, closer to the end of the laterals. The utilities take various measures to maintain and regulate voltage over the entire circuit as per [5], using capacitor bank switching, voltage regulator taps, on-load tap changer transformer, etc. Therefore, the voltage difference between two adjacent measurement points (PMUs) is typically a small percent of the nominal voltage of the circuit. This observation was used to make modifications to the FCP algorithm. The PMUs included on the double-phase or single-phase laterals reconstruct their missing phases by using the reference voltage of the upstream three-phase PMU in their zones. With this philosophy, the voltage sequence components can be calculated for the double-phase and single-phase laterals. The reconstructed voltage needs to qualify certain criteria before the calculated negative-sequence voltage and zero-sequence voltage can be used in the FCP algorithm. The minimum standing zero-sequence and the negative-sequence

magnitudes need to be within a threshold for normal system configuration. Any new circuit where the FCP solution is implemented needs to be reviewed for maximum voltage drop between the substation and the end laterals.

With these enhancements, the FCP solution can be implemented on the three-phase distribution circuit with double-phase and single-phase laterals, as shown in Fig. 2. Zone 1 consists of PMUs that have voltage measurements available for all three phases; therefore, the RTAC will calculate the negative-sequence voltage and zero-sequence voltage magnitudes and angles for PMU1, PMU2, and PMU4 using Equation (1). In Zone 2, the three-phase distribution line branches into double-phase laterals between PMU2 and PMU3. Fig. 3 zooms into Zone 2 from Fig. 2. PMU2 is the zone-referenced PMU of Zone 2; therefore, PMU3 will be referring to PMU2 to reconstruct its missing phase voltage. With the reconstructed voltage for Phase C, the RTAC can calculate the negative-sequence voltage and zero-sequence voltage magnitudes and angles for PMU3 using Equation (2). With this, PMU3 can now participate in the FCP solution using all five voltage-based detection methods.

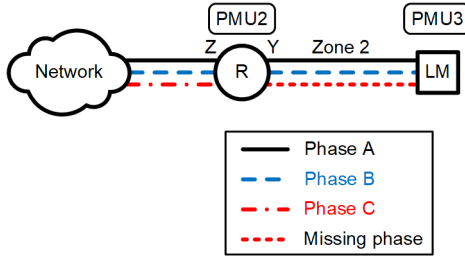

Fig. 3. Zone 2—double-phase lateral.

$$\begin{bmatrix} V_0 \\ V_1 \\ V_2 \end{bmatrix}_{\text{PMU3}} = \frac{1}{3} \begin{bmatrix} 1 & 1 & 1 \\ 1 & \alpha & \alpha^2 \\ 1 & \alpha^2 & \alpha \end{bmatrix} \begin{bmatrix} V_{A_{\text{PMU3}}} \\ V_{B_{\text{PMU3}}} \\ V_{C_{\text{PMU2}}} \end{bmatrix} \quad (2)$$

Similarly, for Zone 3, as shown in Fig. 2, PMU4 is the zone-referenced PMU; therefore, PMU5 refers to PMU4 to reconstruct its missing Phase-B and Phase-C voltages, as shown in Fig. 4. With the reconstructed voltages for Phase B and Phase C, the RTAC can calculate the negative-sequence voltage and zero-sequence voltage magnitudes and angles for PMU5 using Equation (3). With this, PMU5 can now participate in the FCP solution using all five voltage-based detection methods.

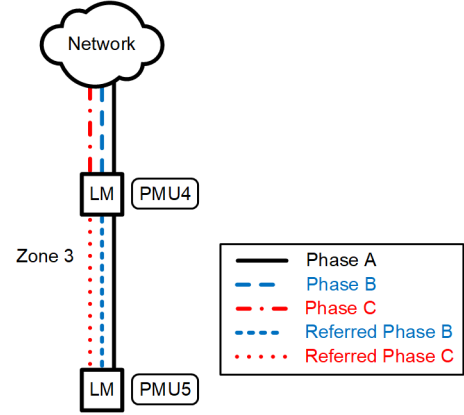

Fig. 4. Zoomed-in view of Zone 3.

$$\begin{bmatrix} V_0 \\ V_1 \\ V_2 \end{bmatrix}_{\text{PMU5}} = \frac{1}{3} \begin{bmatrix} 1 & 1 & 1 \\ 1 & \alpha & \alpha^2 \\ 1 & \alpha^2 & \alpha \end{bmatrix} \begin{bmatrix} V_{A_{\text{PMU5}}} \\ V_{B_{\text{PMU4}}} \\ V_{C_{\text{PMU4}}} \end{bmatrix} \quad (3)$$

Therefore, by reconstructing the missing phase voltages from the zone-referenced PMU, the FCP solution can be implemented on the three-phase distribution circuits with double-phase and single-phase laterals.

C. Security and Reliability

The voltage profile of the circuit needs to be evaluated prior to implementing the FCP solution on three-phase distribution circuits with double-phase and single-phase laterals. The voltage drop between the adjacent PMUs should be within an acceptable range to ensure that the missing phases can be reconstructed from the zone-referenced PMU. Additional supervision and blocking are included within the RTAC FCP library so that any voltage disturbance on a reconstructed phase does not get detected as a true falling conductor in that zone. The PMUs that use the reconstructed voltages for their missing voltage follow the zone-referenced PMU for certain decisions. For example, if the zone-referenced PMU is out of service or not available to participate in the FCP scheme, then the following PMUs on the relevant double-phase or single-phase lateral will automatically follow the referenced PMU and become unavailable to participate in the FCP scheme. This provides the needed security, but it also compromises the circuit coverage for the time that the reference PMU is unavailable.

It is particularly important for a robust scheme to be reliable as well as secure, and this is often a fine balance. The double-phase and single-phase FCP implementation is designed so that it is secure against events such as traditional system faults, capacitor bank switching, voltage regulator taps, manual or automatic breaker open or close, faulty recloser voltage sensors on the source- and load-side showing a mismatch in voltages for a normally closed recloser, or a blown system fuse. These are discussed in detail in [2].

D. Zone Expansion

Several zones of protection are defined to implement the FCP algorithm on a distribution circuit so that there is minimum disruption of service to the customers in the event of a falling

conductor in a particular section of the circuit. The zones are defined so that the affected section of the circuit is completely de-energized and is not backed from any other sections.

Zone expansion occurs when a particular PMU is out of service for any reason, such as for maintenance or if it is out of communication. Typically, for a three-phase circuit, the parent zone expands and covers for the child zone by excluding the PMU that is out of service from the FCP algorithm, thereby extending the coverage [2]. In circuits with double-phase or single-phase laterals, the zone expansion is slightly different. It may be possible that the coverage of the FCP solution reduces during zone expansion scenarios.

As shown in Fig. 5, Zone 2 includes one three-phase lateral with PMU6 at the end of the lateral. It also includes a double-phase lateral with PMU3 at the end of the lateral. With respect to PMU2, Zone 1 is the parent zone. Since PMU3 only has double-phase voltage measurements available, it refers to PMU2 to reconstruct the missing phase voltage. Consider the scenario where PMU2 is out of service. In a typical three-phase distribution circuit, Zone 1 would have expanded to cover Zone 2 in this case. However, since there is a double-phase lateral in this circuit and PMU3 refers to PMU2 to reconstruct its missing phase voltage, when PMU2 is out of service, PMU3 cannot use the reference voltage from PMU2. The RTAC, in this scenario, intentionally disables FCP on PMU3 automatically, and therefore, the coverage is reduced. However, PMU6 is still available to participate in FCP. Zone 1 expands and covers the three-phase lateral of Zone 2.

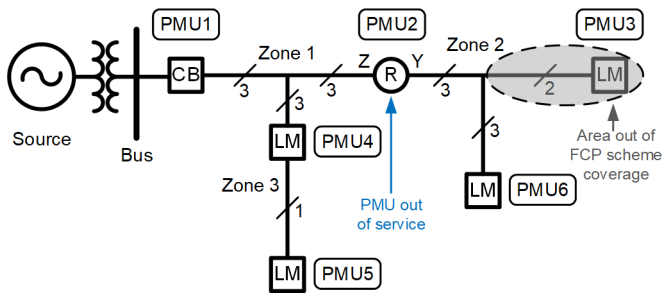

Fig. 5. Modified Fig. 2.

IV. TESTING RESULTS

Extensive laboratory testing as well as field testing was carried out to validate the enhancements made to the existing FCP solution to implement it on double-phase and single-phase laterals. This section dives deeper into the results of the laboratory and field testing of a successful implementation of this scheme on a 12 kV distribution circuit.

A. HIL Testing Results

The RTDS with HIL capability was used to validate the design enhancements in a controlled laboratory environment before field implementation. The 12 kV SDG&E three-phase distribution circuit with double-phase laterals was modeled and provides controls to simulate falling conductors at the desired locations on the distribution circuit in the RTDS software. Fig. 6 shows the modeled 12 kV SDG&E distribution with a total of 13 PMUs. PMU1 is the substation breaker relay, PMU2 is a recloser controller with three-phase voltage measurements available at the source- and the load-side, and PMU3–PMU13 are line monitors. The line monitors do not have tripping capabilities but provide only voltage measurements to extend the FCP coverage on the distribution circuit. This distribution circuit is divided into five FCP zones of protection, as shown in Fig. 6. Zone 1 and Zone 3 are three-phase. Zone 2, Zone 4, and Zone 5 include double-phase laterals. The test locations in each zone are also shown in Fig. 6. The functional trip tests are performed at each location along with different operational and maintenance conditions of the circuit to assess the reliability and security of this scheme in such scenarios. These operational and maintenance tests include manual control of the breaker or recloser, maintenance of PMUs including settings changes, disturbance on the distribution bus that is out of the zone of protection, PMUs that are out of service, and failed communications channels.

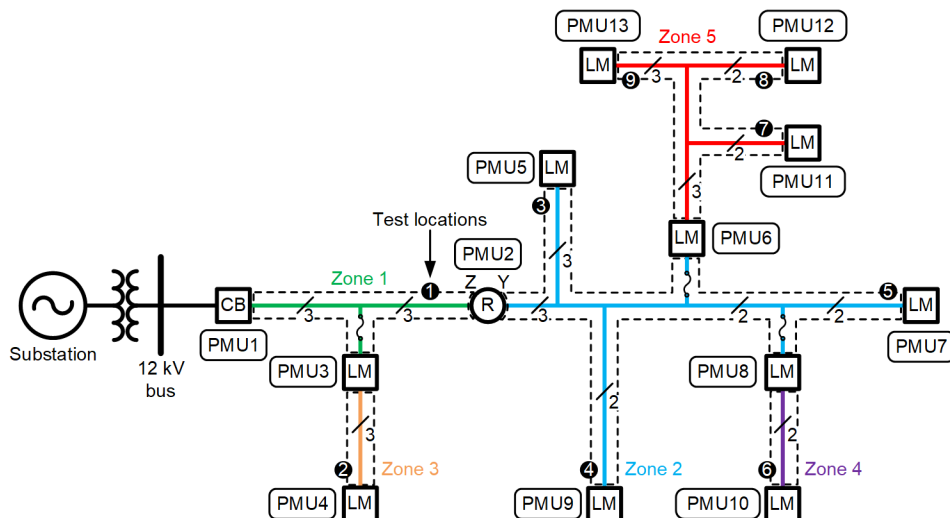

Fig. 6. SDG&E 12 kV distribution circuit modeled in the RTDS software.

Table I shows the FCP zones, zone-referenced PMU for each zone, and the PMUs located on the double-phase laterals that are missing a phase voltage measurement based on the distribution one-line diagram shown in Fig. 6. The PMUs in the double-phase circuits refer to the zone-referenced PMU to reconstruct the missing voltages in the RTAC so that all five voltage-based FCP detection methods can be used to detect a falling conductor.

TABLE I
SDG&E DISTRIBUTION CIRCUIT DEVICE INFORMATION

Zone	Three-Phase PMUs	Zone-Referenced PMU	Double-Phase PMUs
Zone 1	PMU1, PMU2, PMU3	PMU1	—
Zone 2	PMU2, PMU5, PMU6	PMU2	PMU7, PMU8, PMU9
Zone 3	PMU3, PMU4	PMU3	—
Zone 4	—	PMU8	PMU10
Zone 5	PMU6, PMU13	PMU6	PMU11, PMU12

By using RTDS and HIL testing, various scenarios were performed in the lab environment that were impractical to

perform in the field on an in-service distribution network. This rigorous testing helped to validate the protection and control design as well as the enhancement that was in the FCP library.

B. Field Commissioning Results

After the successful validation of the FCP design enhancements in the laboratory environment, field testing was conducted. For field commissioning, [2] provides details on the processes that SDG&E follows. A similar process and steps were followed for this circuit as well. Prior to this circuit, SDG&E has implemented the FCP solution on multiple three-phase circuits that have an Ethernet radio-based or a PLTE-based network environment. The 12 kV distribution circuit discussed in this paper falls under the high fire threat zone.

In the field testing, the RTAC successfully detected the simulated falling conductor condition for all the test locations shown in Fig. 6. The results for three locations (1, 5, and 6) are included in the following sections.

Location 1 is in the three-phase Zone 1, which includes PMU1, PMU2, and PMU3. Fig. 7 shows the phase voltage profile of all the PMUs on this circuit. The falling conductor condition was simulated on Phase A, which caused PMU2 to observe a sag in Phase A, as shown in the top plot of Fig. 7.

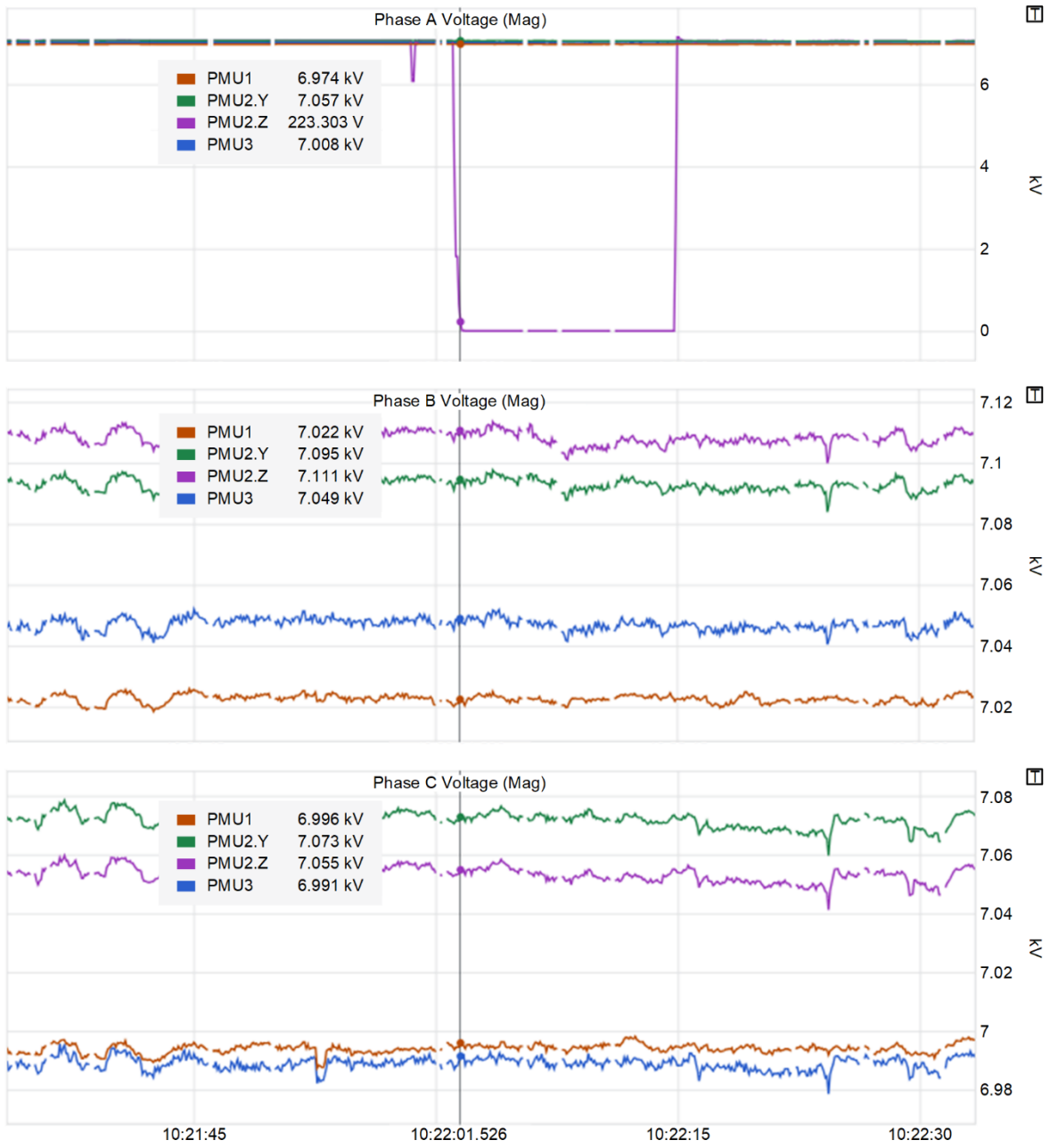

Fig. 7. Test Location 1—phase voltage profile.

The RTAC successfully detected the simulated falling conductor at Location 1 using the detection methods, as shown in the top plot of Fig. 8. Zone 1 was flagged for monitoring SCADA and fault location [2] purposes, as shown in the middle

plot of Fig. 7. Since Zone 1 has an upstream tripping device, which is the substation breaker, the RTAC sent out the GOOSE tripping signal to Zone 1 PMUs (PMU1, PMU2, and PMU3), as shown in the bottom plot of Fig. 8.

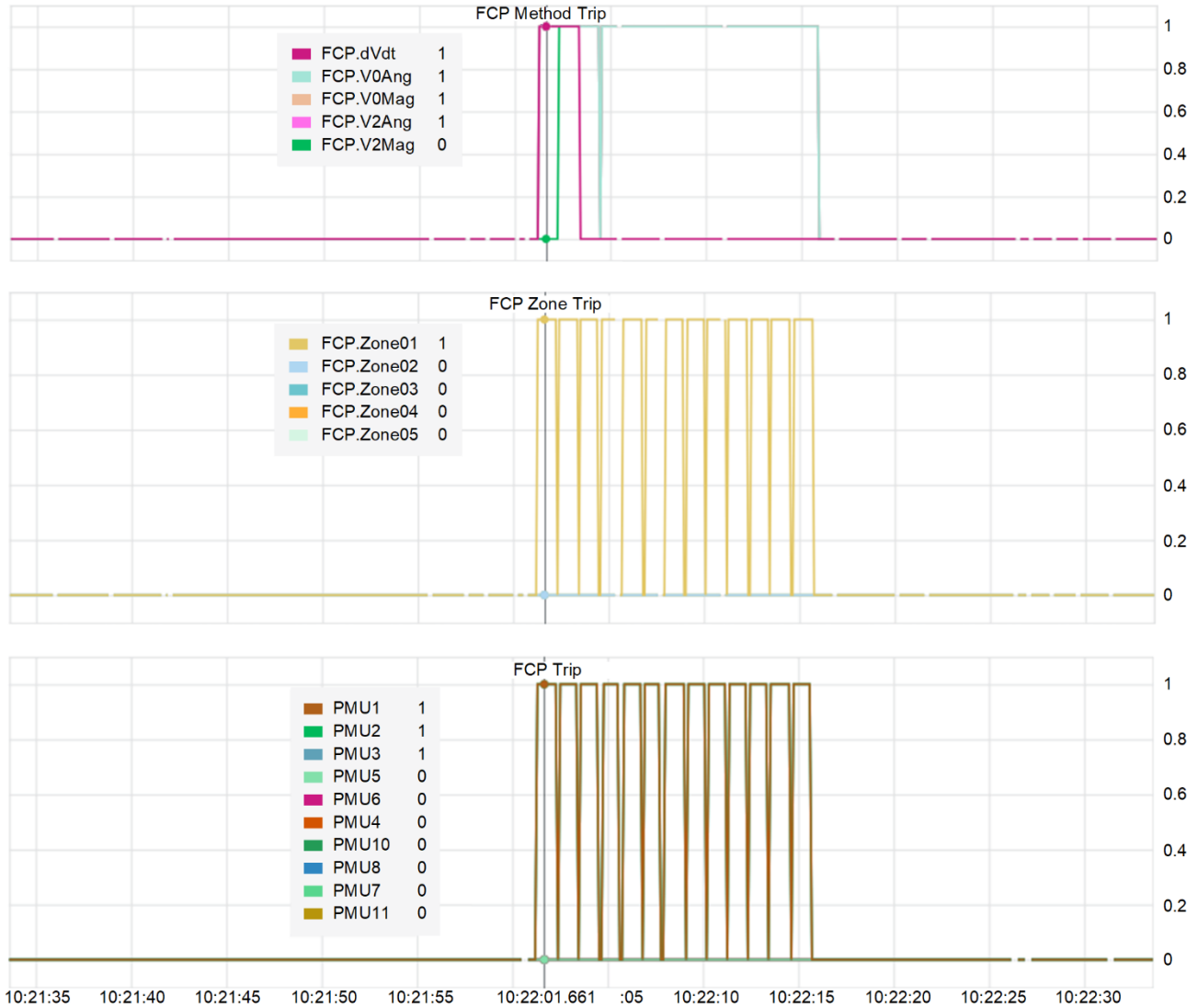

Fig. 8. Test Location 1—FCP trip information.

Location 5 is part of Zone 2, which is a combination of three-phase and double-phase laterals. This test location is on double-phase laterals so PMU7 should be referring to PMU2 for its missing phase voltage, as shown in Table I.

Fig. 9 shows the phase voltage profile of all PMUs when the test was carried out at Location 5. The Phase-A voltage on PMU7 was dropped due to the falling conductor simulation, as shown in the top plot of Fig. 9.

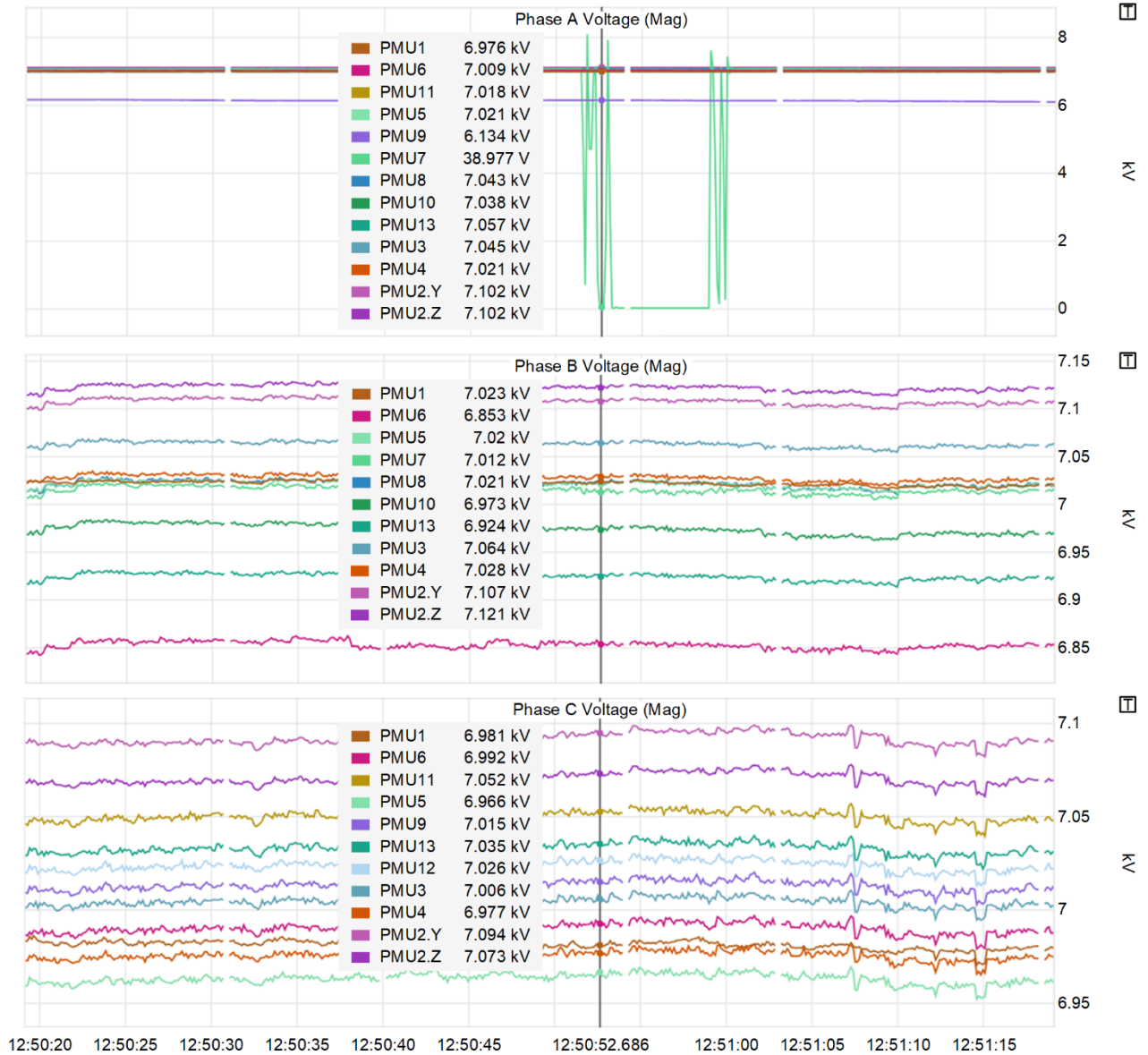

Fig. 9. Test Location 5—phase voltage profile.

The RTAC detected this voltage reduction as a falling conductor condition using different detection methods, as shown in the top plot of Fig. 10. The RTAC successfully identified Zone 2 as the zone in which the falling conductor condition was observed, as shown in the middle plot of Fig. 10.

As Zone 2 has a recloser as a tripping device, the RTAC sent out the GOOSE tripping signal to all the PMUs in Zone 2, which are PMU2, PMU5, PMU6, PMU7, PMU8, and PMU9, as shown in the bottom plot of Fig. 10.

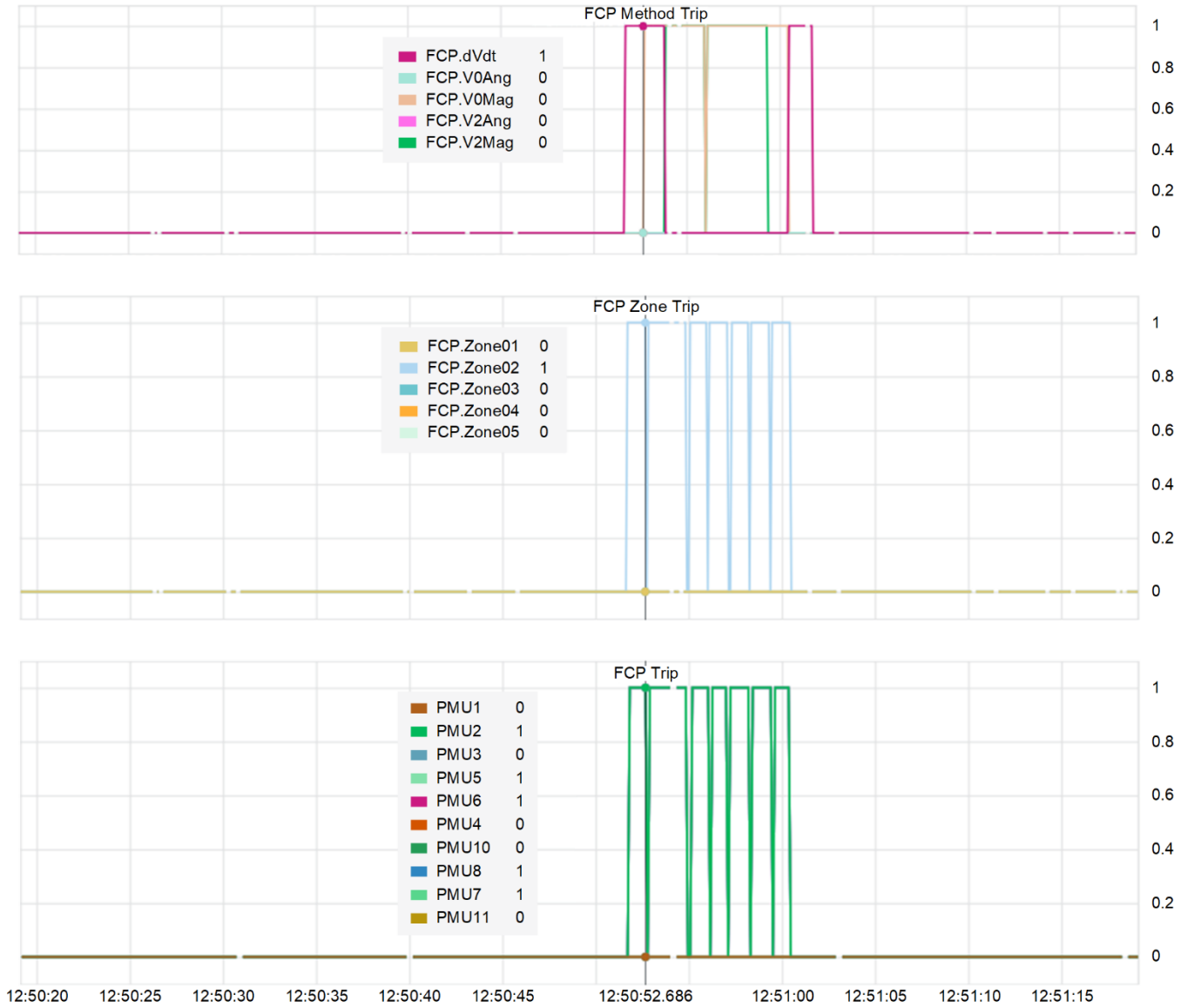

Fig. 10. Test Location 5—FCP trip information.

Test Location 6 is unique because Zone 4 includes only a double-phase lateral and both the PMUs (PMU8 and PMU10) have only double-phase voltage measurements. Therefore, the zone-referenced PMU for Zone 4 is PMU2, the immediate upstream PMU with three-phase voltages available. PMU8 refers to PMU2 to reconstruct its missing phase voltage.

PMU10, in turn, refers to PMU8 to reconstruct its missing phase voltage.

Fig. 11 shows the voltage profile during the testing at Location 6. The falling conductor condition was simulated on Phase A, which caused PMU10 to observe a sag in Phase A, as shown in the top plot of Fig. 11.

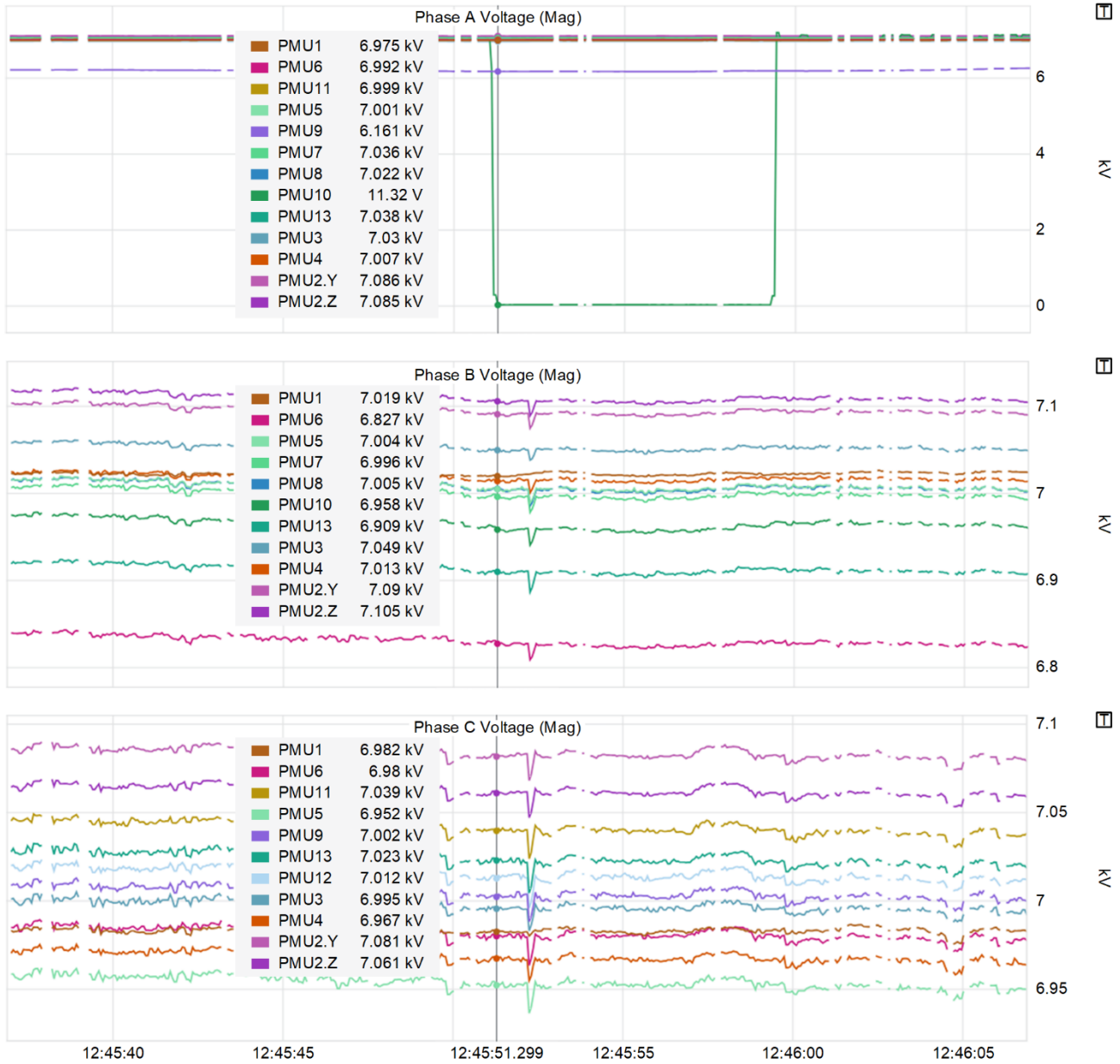

Fig. 11. Test Location 6—phase voltage profile.

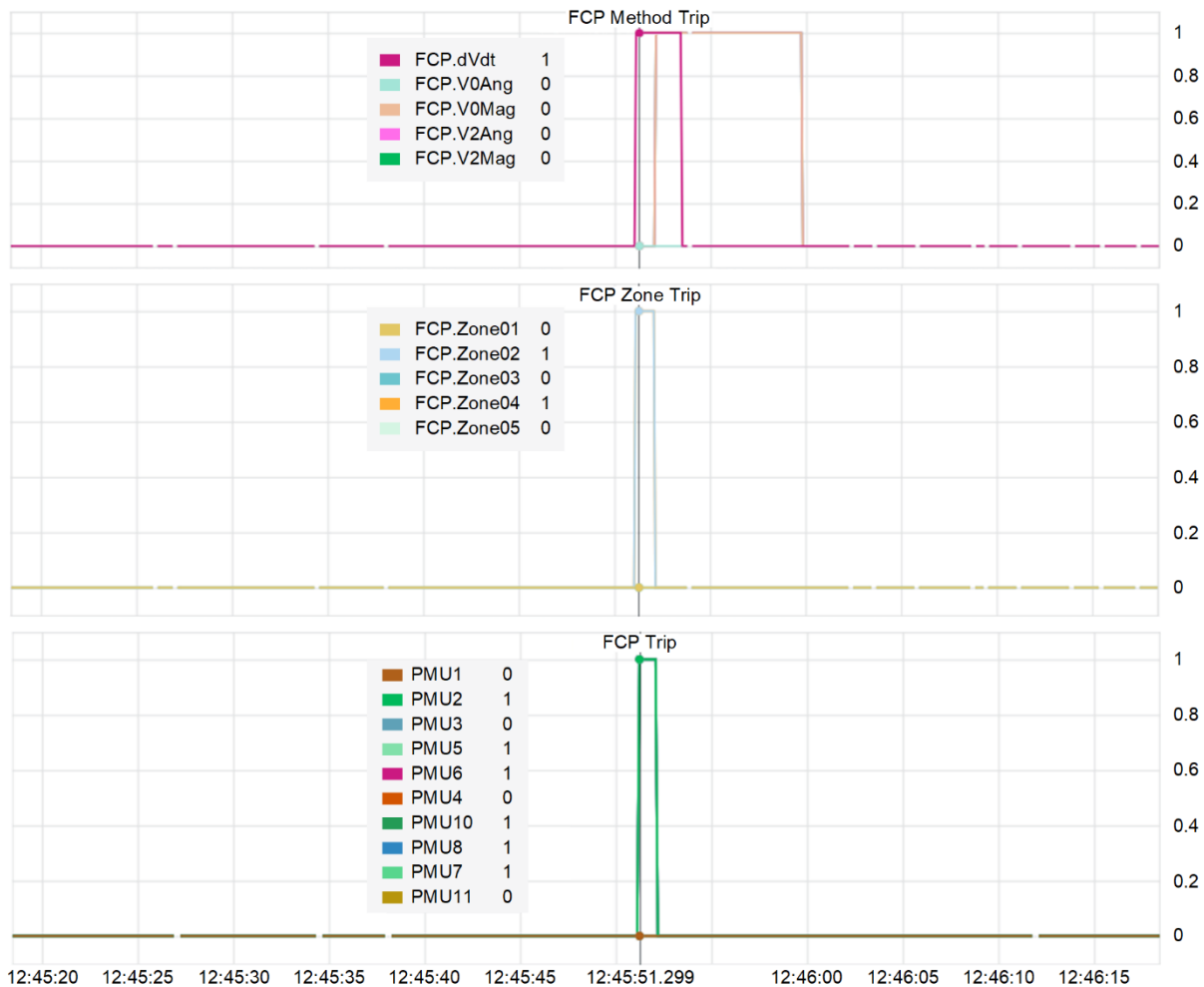

Fig. 12. Test Location 6—FCP trip information.

The RTAC successfully detected the simulated falling conductor at Location 6 using the detection methods, as shown in the top plot of Fig. 12. Since Zone 4 only includes line monitors as PMUs, which do not have an associated circuit breaker to trip, the RTAC issues trip commands to the PMUs in Zone 4 and Zone 2. Zone 2 is the parent zone of Zone 4 and includes the isolation point, PMU2, which trips and de-energizes the affected section, as shown in the middle and bottom plots of Fig. 12.

All the test locations successfully detected the simulated falling conductor condition on the circuit in the field. This 12 kV three-phase distribution circuit with double-phase laterals is in monitoring mode (no tripping of the breaker or recloser and will issue an alarm only upon detection of a falling conductor condition) for an observation period.

V. CONCLUSION

The enhancement made to the existing FCP scheme described in the paper helps when detecting the falling conductors in the double-phase or single-phase laterals as well. The RTDS and HIL testing along with the field commission results presented in the paper validate the enhanced FCP scheme for the distribution network, which is a combination of three-, double-, and single-phase laterals. The enhancement is

security-biased in contingency scenarios if the zone-referenced PMU is out of service. In conclusion, the system study needs to be performed on the circuit to determine if the FCP scheme can be implemented.

So far, this scheme has been successfully implemented on multiple three-phase SDG&E distribution circuits. The methodology used to detect falling conductors in three-phase circuits had to be modified and enhanced to apply it to single-phase and double-phase laterals. Field commissioning and test results have shown that a simulated conductor break can consistently be detected and isolated within 500 ms for both three-phase and double-phase circuits. The authors are excited about future implementations on more circuits and expanding coverage to include laterals that branch off the three-phase circuits.

VI. ACKNOWLEDGMENTS

The authors gratefully acknowledge the contributions of Kamal Garg, Chris Bontje, Jay Lopes, and Abdallah Smadi of Schweitzer Engineering Laboratories, Inc. for their exceptional contributions throughout the development and testing phases of this project. The authors also appreciate the support and assistance from Jorge Esmerio of San Diego Gas & Electric

Company during the commissioning and field implementation of this project.

design, SEL product integration, automation products, and commissioning support. David joined SEL Engineering Services, Inc. (SEL ES) in May of 2021 as an automation engineer.

VII. REFERENCES

- [1] W. O'Brien, E. Udren, K. Garg, D. Haes, and B. Sridharan, "Catching Falling Conductors in Midair – Detecting and Tripping Broken Distribution Circuit Conductors at Protection Speeds," proceedings of the 69th Annual Conference for Protective Relay Engineers, College Station, TX, USA, April 2016.
- [2] C. Cerezo, C. Murphy, T. Doshi, R. Sharma, and J. Lopes, "Detecting and Isolating Falling Conductors in Midair – First Field Implementation Using Private LTE at Protection Speeds," proceedings of the 76th Annual Conference for Protective Relay Engineers, College Station, TX, March 2023.
- [3] Y. Gong, G. Juvekar, and K. Dase, "Zero-Setting Broken Conductor Detection Method Using Local Measurements Only," proceedings of the 50th Annual Western Protective Relay Conference, Spokane, WA, October 2023.
- [4] Y. Yin, H. Bayat, N. Dunn, M. Webster, A. Marquez, K. Tran, and A. Torres, "High-Speed Falling Conductor Protection for Electric Power Transmission Systems," proceedings of the 49th Annual Western Protective Relay Conference, Spokane, WA, October 2022.
- [5] ANSI C84.1, *Electric Power Systems and Equipment—Voltage Ratings (60 Hz)*, 2020.

VIII. BIOGRAPHIES

Charlie Cerezo graduated with a Bachelor of Science degree in Electrical Engineering from California State Polytechnic University, Pomona, and is a licensed professional engineer in the state of California. He is a system protection and controls engineer with San Diego Gas & Electric Company (SDG&E). Presently, he is one of the project engineers for the SDG&E Advanced Protection Program (APP), which develops and implements advanced protection technologies within electric substations and on electric distribution systems.

Tanushri Doshi received her MS degree in electrical engineering from Arizona State University and her BTech in electrical engineering from the Visvesvaraya National Institute of Technology, Nagpur. Tanushri joined Schweitzer Engineering Laboratories, Inc. (SEL) in 2011 as an associate protection engineer. Presently, she is working as an engineering manager for the protection group in the SEL Engineering Services, Inc. division. Tanushri has experience in power system protection design, relay settings, wildfire mitigation solutions, synchrophasors, commissioning, and testing. She has designed and implemented protection and control schemes with hardware-in-the-loop testing using a real-time digital simulator. She is a registered professional engineer (PE) in the states of Arizona and Montana and a senior IEEE member.

Rohit Sharma earned an MS degree in electric power system engineering from North Carolina State University in 2020 and a Bachelor of Technology degree in electrical engineering from Sardar Patel College of Engineering in Mumbai, India, in 2017. He is a power system protection engineer in the protection group in the SEL Engineering Services, Inc. division with Schweitzer Engineering Laboratories, Inc. (SEL). He joined SEL in 2021. He has experience in power system modeling, power system studies, hardware-in-the-loop (HIL) testing using real-time digital simulators (RTDSs), power system protection design, event analysis, and relay settings.

Joe Stanley received both his MEng and Bachelor of Science in Electrical Engineering while studying at the University of Idaho. Joe has experience in real-time software development, firmware system architecture and design, communications network design, and application configuration design. He joined Schweitzer Engineering Laboratories, Inc. (SEL) in 2016 and now serves as a lead automation engineer for the SEL research and development group focusing on development of automation and real-time control systems.

David Almendarez graduated with a Bachelor of Science in Mechanical Electrical Engineering from Universidad Autónoma de San Luis Potosí in San Luis Potosí, Mexico, in 2015. David has experience in power systems protection and automation, supervisory control and data acquisition (SCADA)