

A Call to Action: Say YES to Restricted Earth Fault Protection

Swagata Das, Ariana Hargrave, Marcel Taberer, and Michael J. Thompson,
Schweitzer Engineering Laboratories, Inc.

Abstract—On a particularly eventful day at an industrial facility, a ground fault on a wye-side bushing of a delta-wye grounded transformer went undetected by the phase differential (87R) element in the relay protecting the transformer. The transformer was grounded through a neutral grounding resistor (NGR) to create a low-impedance grounded system. A few seconds into the fault, the NGR failed and created a short to ground. This change in grounding caused the phase currents to dramatically increase and the 87R element to operate.

Unfortunately, this type of event is not an isolated case. The authors have seen several field events where the 87R element failed to trip for a ground fault on a low-impedance grounded transformer. The same questions are always asked after these events: Why didn't the 87R element operate? Can another element in the relay be enabled to detect this type of fault and operate quickly?

In this paper, we explain how certain ground faults (those in low-impedance grounded transformers or those close to the neutral of the wye winding in solidly grounded transformers) may not produce phase currents large enough to assert the 87R element. We provide three quick-check equations that can be used to calculate the winding coverage of the 87R element for delta-wye low-impedance grounded transformers. We then describe how restricted earth fault (REF), another element available in most transformer relays, can complement the 87R element and provide increased sensitivity for ground faults in both solidly grounded and low-impedance grounded transformers. We explain how REF works, how it should be set, and how it should be commissioned to avoid common installation errors.

REF protection has been available to the industry for decades but is not commonly applied. This could be due to engineers not understanding the purpose, importance, and simplicity of this element because descriptions of the element can appear overly complicated. This paper aims to fill the gap and serves as a renewed call to action for the industry to use REF elements to increase the dependability, sensitivity, and speed of ground fault protection in transformer relays.

I. INTRODUCTION

Transformers are some of the most critical assets of a power system. They are found at all voltage levels in both utility and industrial systems. When a fault occurs on a transformer, it is essential to clear the fault as quickly as possible to prevent further damage to the transformer, personnel injuries, and environmental disasters (fires, oil spills, etc.).

Transformers can experience many different types of faults [1]. To detect these faults, a phase differential (87R) element is typically used for transformers rated 10 MVA and above [2]. While the 87R element can detect most faults in the transformer, it has difficulty detecting ground faults close to the neutral on solidly grounded transformers as well as those

anywhere in the wye side of the transformer protection zone on low-impedance grounded transformers. The wye side of the protection zone includes the entire wye winding, as well as the buswork up to the zone boundary current transformers (CTs).

For ground faults close to the neutral in solidly grounded transformers, a small portion of the transformer winding is shorted to ground. This small change in the winding does not have a substantial impact on transformer operation and does not significantly change the phase currents. Although these faults produce low-magnitude phase currents, they must be quickly detected and isolated as the ground current circulating through the shorted turns can be very high and can cause significant damage to the transformer if allowed to persist. Unfortunately, the low-magnitude phase currents make it difficult for the 87R element to detect these faults.

For in-zone phase-to-ground faults anywhere in the wye side of a low-impedance grounded transformer, the phase and ground currents circulating through the shorted turns are limited by the neutral grounding resistor (NGR). These currents are small for faults at the terminals and become even smaller as the fault moves closer toward the neutral. Even though these faults produce low-magnitude phase and ground currents, they must still be detected to prevent damage to the NGR and subsequent damage to other power system equipment. Again, the low-magnitude phase currents make it difficult for the 87R element to detect these faults [3].

One solution to detect ground faults in grounded wye windings of transformers is to use a neutral time-delayed overcurrent element set to coordinate with downstream ground protection [4]. Slow fault clearing times due to this time delay can, however, lead to catastrophic failures in transformers as described in [5].

A better solution to avoid long time delays is to use a restricted earth fault (REF) element. The REF element has been available in transformer relays for decades but is not commonly applied, as many engineers believe that REF is an optional auxiliary function and that the 87R element alone will protect for all faults in the transformer zone. They may also be afraid to apply it due to the fear of misoperations caused by wiring errors. Other common misconceptions are that REF schemes are complicated and difficult to set or commission. This paper aims to dispel these misconceptions and prove that REF is a simple element that is easy to set and commission and that overlooking its importance may leave transformers vulnerable to ground faults.

In this paper, we first review the basics of 87R protection and explain why it may not be able to detect certain ground faults in transformers. We provide three quick-check equations that can be used to calculate the winding coverage of an 87R element for delta-wye low-impedance grounded transformers. Next, we explain how REF works, how to set it, and how it improves winding coverage for ground faults. We then show a field event where the 87R element failed to operate for a ground fault that resulted in significant damage to power system equipment. We explain why the 87R element did not operate, how the quick-check equations could have been used to discover this lack of sensitivity during initial settings development, and how a REF element would have helped clear the fault quickly had it been enabled. Finally, we show how a REF element should be commissioned to avoid common installation errors.

II. REVIEW OF 87R PROTECTION

This section presents an overview of the 87R element. This overview is necessary to understand the quick-check equations in Section III for calculating 87R winding coverage as well as the event analysis in Section V. For more details about the 87R element, refer to [6], [7], and [8].

An 87R element in a transformer relay compares the phase currents entering the protection zone to the phase currents leaving the protection zone. Fig. 1 shows the 87R element logic for a two-winding transformer.

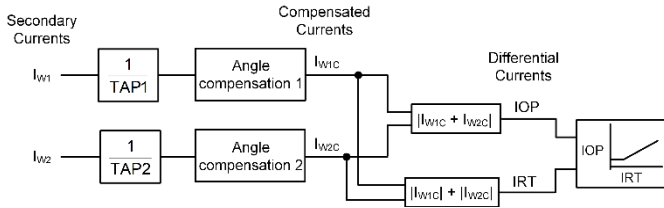

Fig. 1 Relay logic for an 87R element.

CTs connected with differential polarities measure the phase currents from both sides of the transformer and bring them into the relay as I_{w1} and I_{w2} . The two currents are adjusted by their TAP and angle compensation settings to make the resultant currents, shown as “compensated currents,” equal in magnitude and 180 degrees out of phase for normal load or external fault conditions.

The compensated currents are then used to calculate operating (IOP) and restraining (IRT) currents in pu. Fig. 1 shows one method of calculating these currents, but the equations can vary depending on relay design.

The calculated IOP and IRT currents are then used to plot a point on a percentage-restrained differential characteristic, as shown in Fig. 2, on a per-phase basis ($p = A, B, \text{ or } C$). The differential characteristic is defined by a minimum operate threshold (O87P) and a slope (SLP).

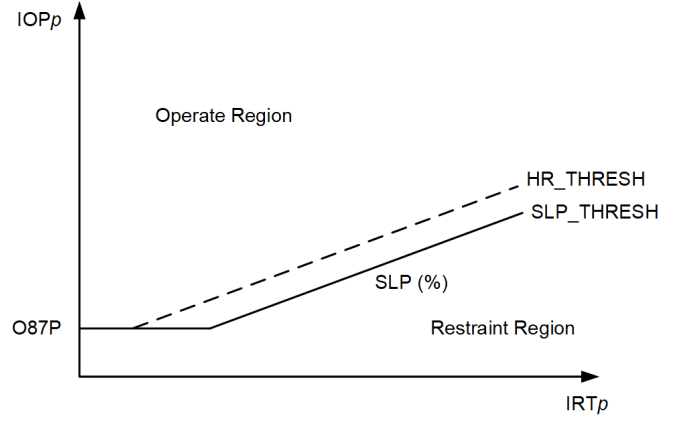

Fig. 2 A simple percentage-restrained differential characteristic.

The 87R element operates when the calculated values of IOP and IRT plot above the O87P threshold as well as the SLP threshold (SLP_THRESHOLD). Mathematically, this translates to the 87R element operating when (1) is true.

$$\begin{aligned} IOP_p &> \max [O87P, SLP_THRESH] \\ SLP_THRESH &= \frac{SLP}{100} \cdot IRT_p \end{aligned} \quad (1)$$

A common method of securing the 87R element during inrush conditions is to use harmonic restraint. This method adds a set amount of the measured second and fourth harmonic content of the IOP current to the SLP threshold, resulting in a new threshold, HR_THRESHOLD, shown by the dashed line in Fig. 2. Mathematically, this translates to the 87R element operating when (2) is true.

$$\begin{aligned} IOP_p &> \max [O87P, HR_THRESH] \\ HR_THRESH &= SLP_THRESH + k_2 \cdot IOP_{p2H} + k_4 \cdot IOP_{p4H} \end{aligned} \quad (2)$$

where:

k_2 is the scaling constant for the second harmonic, equal to $100/PCT2$ where PCT2 is a setting in the relay.

IOP_{p2H} is the second harmonic content of IOP_p in pu.

k_4 is the scaling constant for the fourth harmonic, equal to $100/PCT4$ where PCT4 is a setting in the relay.

IOP_{p4H} is the fourth harmonic content of IOP_p in pu.

III. UNDERSTANDING AND CALCULATING 87R SENSITIVITY TO GROUND FAULTS

In this section, we will explain how fault location and transformer grounding affect the sensitivity of the 87R element to ground faults on wye windings of transformers. We are also going to show how to quickly determine what percentage of the wye winding is protected by the 87R element. The equations are given for a delta-wye low-impedance grounded transformer but can be adapted to other transformer types.

A. The Effect of Fault Location on 87R Sensitivity

Consider an ideal, unloaded, solidly grounded, two-winding, single-phase transformer with the same number of turns on the primary and secondary windings, as shown in Fig. 3. A ground fault exists at x percent of the secondary winding. N_C is the number of turns from the bottom of the winding to the fault, and N_S is the number of turns from the fault to the top of the winding.

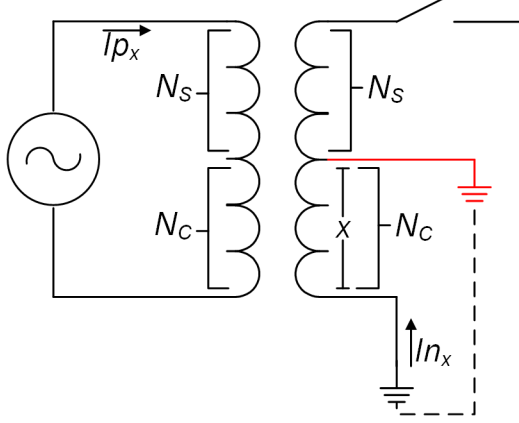

Fig. 3 Ground fault on the secondary side of a single-phase transformer.

The voltage source connected to the primary winding induces a voltage across the secondary winding. This voltage is distributed uniformly across the turns of the secondary winding. Therefore, the voltage at the fault point depends on the location of the fault within the winding.

The voltage at the fault point causes current I_{n_x} to circulate to ground and up the neutral to the fault point through N_C turns. Since the transformer is unloaded and no current flows through N_S turns on the secondary winding, this section of the secondary winding can be ignored. What remains is the full primary winding ($N_S + N_C$ turns) with I_{p_x} current flowing through it and a section of the secondary winding (N_C turns) with I_{n_x} current flowing through it.

To satisfy ampere-turns balance, the number of ampere-turns on the primary winding must equal the number of ampere-turns on the secondary winding. Therefore, (3) is true.

$$I_{p_x} \cdot (N_S + N_C) = I_{n_x} \cdot N_C \quad (3)$$

Solving for I_{p_x} , we get (4).

$$I_{p_x} = \frac{N_C}{N_S + N_C} \cdot I_{n_x} \quad (4)$$

If the pu distance to the fault from the bottom of the winding is defined as (5),

$$x = \frac{N_C}{N_S + N_C} \quad (5)$$

then I_{p_x} can be written as (6).

$$I_{p_x} = x \cdot I_{n_x} \quad (6)$$

Equation (6) is valid for a single-phase transformer with a 1:1 turns ratio. For a transformer with a transformation ratio of TR, (6) changes to (7).

$$I_{p_x} = x \cdot I_{n_x} \cdot TR \quad (7)$$

Equation (7) is also true for a three-phase transformer, where I_{p_x} is the phase current on the primary side of the transformer and I_{n_x} is the ground current on the secondary side of the transformer. The discussion from this point onward will assume a three-phase transformer.

Equation (7) shows that I_{p_x} is a multiple of I_{n_x} , which is directly proportional to the distance to the fault from the neutral. If the fault is closer to the neutral (x is small), I_{p_x} is a small multiple of I_{n_x} . For example, if a fault were to occur at 10 percent of the winding from the neutral ($x = 0.1$ pu), then I_{p_x} will be 10 percent of I_{n_x} , adjusted for the transformation ratio. This shows that for a ground fault close to the neutral, the phase current is much smaller than the ground current. Because the 87R element uses the phase current and not the ground current to operate, it may not be sensitive enough to detect faults close to the neutral.

B. The Effect of Transformer Grounding on 87R Sensitivity

This subsection will show how transformer grounding affects I_{p_x} and therefore the 87R element sensitivity to ground faults.

1) Low-Impedance Grounded Transformers

Consider an unloaded, three-phase, low-impedance grounded transformer on a radial system with a ground fault on the wye-connected secondary terminal. The ground current that flows during the fault (I_{n100}) is equal to the nominal line-to-neutral voltage divided by the impedance of the NGR (R_n), as shown in (8). Note that the source and transformer impedances are much smaller than R_n and are thus neglected in (8).

$$I_{n100} = \frac{(kV_{LL} / \sqrt{3}) \cdot 1,000}{R_n} \quad (8)$$

Equation (8) is valid for a ground fault at the terminal of the wye winding. For ground faults inside the winding (at x pu distance from the neutral), the fault current reduces because the voltage at the fault point is no longer the nominal line-to-neutral voltage. Instead, it is multiplied by x pu. This allows us to calculate I_{n_x} for a fault anywhere on the winding as (9).

$$I_{n_x} = x \cdot \frac{(kV_{LL} / \sqrt{3}) \cdot 1,000}{R_n} \quad (9)$$

We can write (9) in terms of (8) as (10).

$$I_{n_x} = x \cdot I_{n100} \quad (10)$$

We can write (7) in terms of maximum ground current by substituting (10) into (7) to get (11).

$$I_{p_x} = x^2 \cdot I_{n100} \cdot TR \quad (11)$$

Fig. 4 shows a graph of I_{n_x} and I_{p_x} for fault locations along the winding of a low-impedance grounded transformer with $TR = 1$ [9]. The blue dotted line shows that the ground current I_{n_x} is highest at the terminal and decreases linearly from this value as the fault moves closer toward the neutral. The red solid line shows that the phase current I_{p_x} is equal to I_{n_x} for a fault at the terminal and decreases as the square of the fault distance as the fault moves closer toward the neutral.

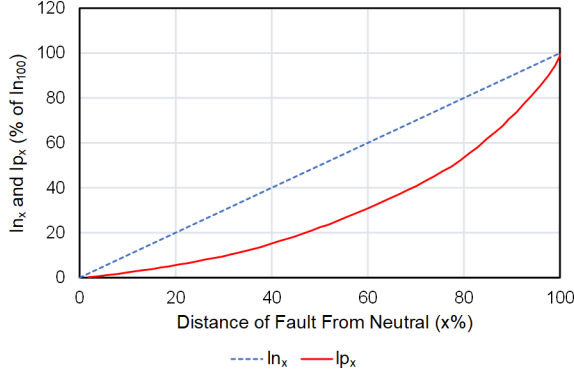

Fig. 4 I_{n_x} and I_{p_x} for ground faults along the winding of a low-impedance grounded transformer with $TR = 1$ [9].

As seen in Fig. 4, for low-impedance grounded transformers, the highest ground current is when the fault occurs at the terminal of the transformer, i.e., 100 percent of the winding ($I_{n_{100}}$). The phase current seen by the 87R element is also the highest at this location ($I_{p_x} = I_{n_{100}}$). Because $I_{n_{100}}$ is small due to the existence of the NGR, the highest possible I_{p_x} will also be small. This means that the 87R element may not be able to detect ground faults at the terminal of a low-impedance grounded wye winding or on the buswork between the transformer terminal and the associated CTs, much less within the winding itself.

2) Solidly Grounded Transformers

Consider an unloaded, three-phase, solidly grounded transformer on a radial system with a ground fault on the wye-connected secondary terminal. Assuming an infinite bus, the ground current for a fault at the terminal of the wye winding can be easily calculated from the nominal line-to-neutral voltage and the transformer impedance (Z_T). However, the ground current for a fault within the winding is more difficult to calculate as Z_T is not linear and its value at a specific point on the winding depends on various factors [1]. The ground current values for faults within the winding can be obtained through placing actual faults on a transformer and taking measurements in a laboratory environment or by performing software simulations. Reference [10] shows one software package capable of adequately performing these simulations.

The blue dotted line in Fig. 5 shows I_{n_x} for faults at different locations along the wye winding of a solidly grounded transformer [9]. Notice that I_{n_x} is nonlinear and quite high when the fault is close to the neutral or close to the terminal. Although its value is smaller when the fault is in the middle region of the winding, the current here is still significant, more than five times full load amperes (FLA) in this example.

The red solid line shows I_{p_x} calculated from I_{n_x} using (7). When the fault is at the terminal, I_{p_x} equals I_{n_x} ($TR = 1$) and is quite significant (10 times FLA in this example). I_{p_x} is significant for faults along the majority of the winding but becomes small for faults very close to the neutral. This means that the 87R element can easily detect ground faults along the majority of a solidly grounded wye winding but may not be able to detect faults very close to the neutral.

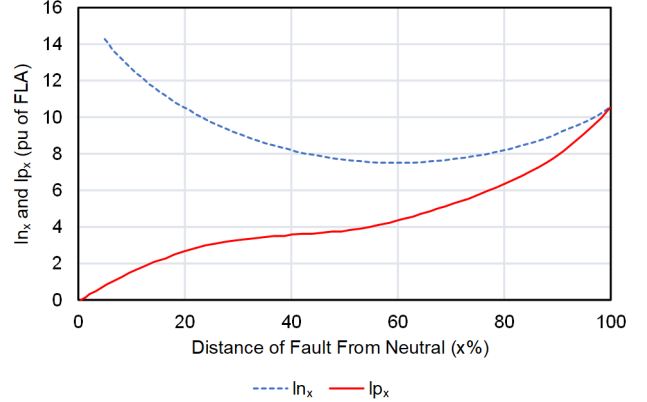

Fig. 5 I_{n_x} and I_{p_x} for ground faults along the winding of a solidly grounded transformer with $TR = 1$ [9].

C. Calculating 87R Winding Coverage

1) Low-Impedance Grounded Transformers

For low-impedance grounded transformers, the 87R element may not detect faults anywhere on the wye side of the transformer protection zone. It is possible to detect this lack of sensitivity during settings development by calculating the winding coverage of the 87R element.

The equations to calculate 87R winding coverage ($87R_C$ percent) are derived in Appendix A for a delta-wye low-impedance grounded transformer with the source on the delta side and load on the wye side. The equations are derived for three conditions: no load, rated load, and energization. The coverage begins at the zone boundary CTs and extends toward the neutral.

Solving these equations will show that the 87R winding coverage is lowest during rated load and energization. This is due to the restraint threshold being raised by load and harmonics, which make it even harder for the low phase currents from the fault to cause an 87R element operation.

We recommend starting with the no load equation given by (12) to determine the best possible winding coverage of the 87R element based on its settings. If $87R_C$ percent works out to be a negative number, indicating that the 87R element will not be able to detect any ground faults on the wye side of the transformer zone, no further winding coverage calculations are necessary.

$$87R_C \% = 100 \cdot \left(1 - \sqrt{\frac{\sqrt{3} \cdot 0.87P \cdot CTR_P \cdot TAP_P \cdot R_n}{1,000 \cdot kV_{LL} \cdot TR}} \right) \quad (12)$$

where:

CTR_P is the CT ratio on the primary delta winding.

TAP_P is the TAP setting for the primary delta winding.

If $87R_C$ percent works out to be a relatively small positive number (very limited coverage), consider applying (43) to check the $87R$ coverage during rated load (as that is the condition the transformer will be in for most of its life). In most cases, the $87R$ element will not provide adequate coverage.

The energization equation in (50) is useful during post-fault analysis to determine the $87R$ winding coverage when second harmonics are known. The coverage calculated using this equation is only going to be true when the transformer is experiencing inrush.

2) Solidly Grounded Transformers

For solidly grounded transformers, the $87R$ element will be sensitive enough to detect faults along most of the winding (as explained in the previous subsection). The element's sensitivity, however, will be challenged for faults very close to the neutral. To calculate the $87R$ element sensitivity in terms of winding coverage, we need to know I_{n_x} (and the corresponding I_{p_x}) at various locations within the winding. The software tool described in [10] can be used to estimate I_{n_x} and calculate the approximate coverage of the $87R$ element as shown in [11].

D. Summary

This section showed that for solidly grounded transformers, I_{p_x} is small for ground faults very close to the neutral of the wye winding. For low-impedance grounded transformers, I_{p_x} is small for all ground faults, even those at the terminals. The low value of I_{p_x} reduces the $87R$ element sensitivity for these faults. The previous subsection shows how engineers can determine the incomplete coverage provided by their $87R$ element.

In contrast, there is always enough I_{n_x} for ground fault detection, regardless of the type of transformer grounding or distance of the fault from the neutral. In the next section, we will describe an element (REF) that uses I_{n_x} instead of I_{p_x} as its operating quantity, making it superior for ground faults. The REF element should be used to complement the $87R$ element for all transformers, and together, they will provide increased sensitivity for ground faults all along the wye winding.

IV. REF PROTECTION

A REF element is used to detect ground faults on grounded wye transformer windings. The name "restricted" comes from the fact that the element's protection zone is restricted to the area between the ground CT and the zone boundary CTs, as shown in Fig. 6. Because the zone of protection is restricted, this element is relatively fast, as it does not require coordination with downstream ground protection.

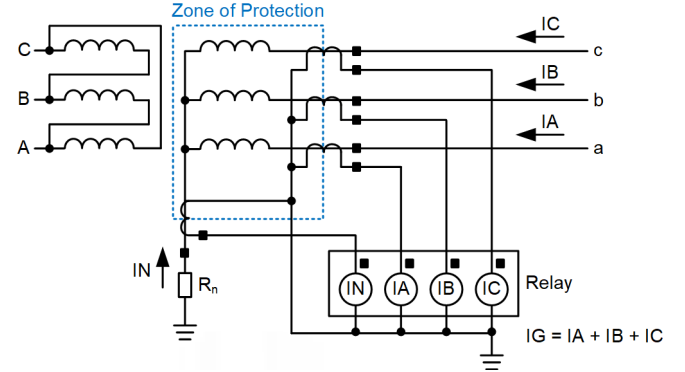

Fig. 6 REF protection on the wye side of a delta-wye transformer.

The REF element is intended to fill the gaps in $87R$ coverage for ground faults on the wye winding. This includes ground faults near the neutral of solidly grounded transformers, and anywhere between ground and zone boundary CTs of low-impedance grounded transformers. The REF element is not intended to detect ground faults on high-impedance grounded transformers. Voltage-based schemes are typically used for such applications.

REF protection can be applied using low-impedance schemes (ground differential elements and current-polarized directional overcurrent elements) and high-impedance differential schemes [2] [12]. This section is going to focus on the current-polarized directional overcurrent REF element. It explains how the element works, how to set it, and how to calculate its sensitivity to ground faults.

A. Understanding Basic REF Element Logic

It is important to understand that the logic diagrams presented in this section are simplified to illustrate the basic functionality of the REF element. The diagrams found in relay manuals that describe specific implementations will typically be more detailed and will have different variable names [13] [14] [15].

The logic for a current-polarized directional overcurrent REF element is shown in Fig. 7. The output of the first comparator, REF_50N, indicates that there is a ground fault on the system if the current measured by the ground CT, IN in Fig. 6, is greater than a user-settable tripping threshold, 50NP. Because the IN current is measured by a single CT and is immune from fictitious residual current caused by CT errors, the assertion of REF_50N indicates that there is a ground fault somewhere on the system on the wye side of the transformer. This is key to the inherent security of the REF element, as will be discussed later in Subsection IV.D.

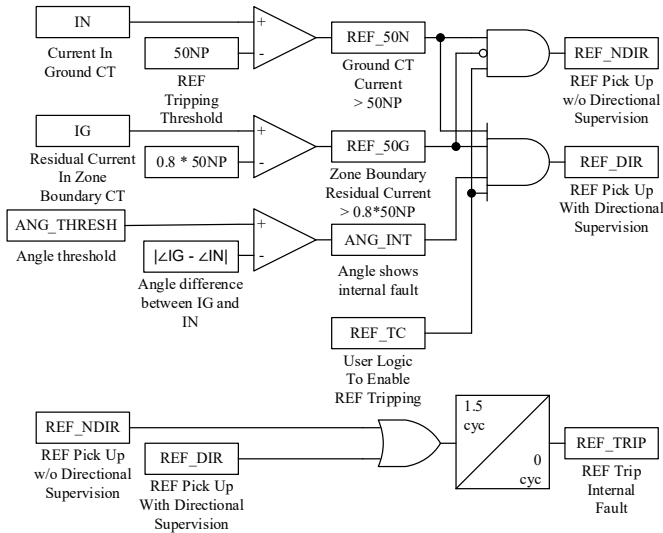

Fig. 7 Logic for a current-polarized directional neutral overcurrent REF element.

The output of the second comparator, REF_50G, indicates if the residual current measured at the zone boundary, IG in Fig. 6, is large enough that what is entering the zone from the ground CT may be leaving the zone per Kirchhoff's current law. A 0.8 margin factor is applied to the 50NP REF tripping threshold.

If REF_50G does not assert, the ground fault can be declared as internal and the non-directional pickup logic, REF_NDIR, asserts. This non-directional path is required to cover the case when the zone boundary breaker is open, or when feeding a radial system with no ground source on the wye side.

If REF_50G asserts, then one of two things are true: (1) the fault current is flowing up the neutral and out the zone boundary (an external fault, shown in Fig. 8 (a)), or (2) the fault current is flowing into the protection zone from external ground sources (an internal fault, shown in Fig. 8 (b)). To determine if the fault is internal, the third comparator in Fig. 7 compares the angle between IN and IG. ANG_INT and REF_DIR assert for an internal fault. This is referred to as the directional path.

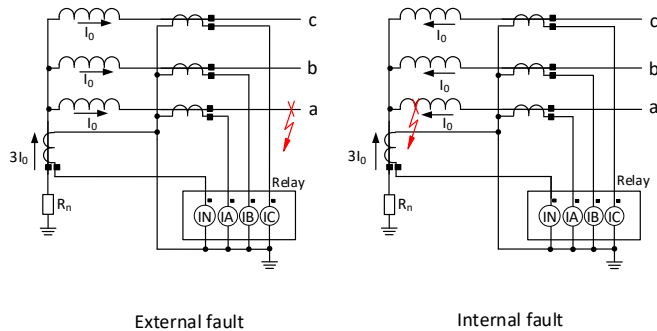

Fig. 8 Ground fault current flow in the wye winding for external (a) and internal (b) faults.

The angle check between IN and IG can be understood using Fig. 8 and Fig. 9. With CTs wired with differential polarities, the relay should ideally measure IN and IG to be 180 degrees out of phase for an external fault and in phase for an internal fault. A traditional REF element uses a ± 90 degree boundary (ANG_THRESH of 90 degrees) to differentiate between internal and external faults, as shown in Fig. 9. A “dead zone” is usually included around the ± 90 degree boundary where no decision is made, as shown in Fig. 9.

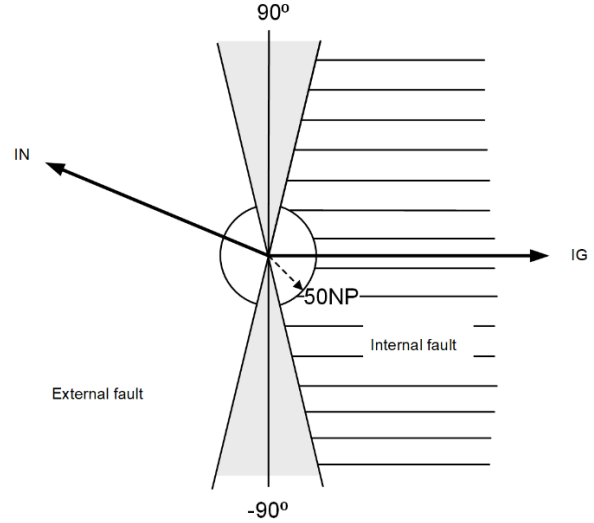

Fig. 9 Angle check with traditional REF element.

A torque control supervision (REF_TC) is included in the Fig. 7 logic for both the REF_NDIR and REF_DIR paths. Possible uses for this supervision are described in Subsection IV.D.

When REF_50N asserts and is allowed to pass through either the REF_NDIR or REF_DIR logic, REF_TRIP asserts after a short time delay of 1.5 cycles and is used to trip the transformer. The time delay allows the element to ride through transient system conditions that can temporarily appear as internal faults, such as the operation of an in-zone surge arrester.

To implement a REF element, the zone boundary CTs must be connected in wye to measure IG. The CTs on the ground and the terminal side do not need to have the same ratio since relay logic scales the zone boundary currents to primary amperes and then converts them to pu (on the IN base). This scaling of the currents allows IG and IN to be directly compared despite being measured by CTs with different ratios.

B. Setting the Pickup

The only setting that must be calculated for the REF element is the 50NP pickup setting. This setting is in pu of the neutral CT rated current (I_{NOM_CTRN}) and must be set greater than maximum unbalance current (I_{unbal}) and the minimum current required for measurement accuracy (I_{min}) [15]. I_{unbal} and I_{min} are in primary amperes and are divided by the neutral CT rated current to obtain the 50NP setting in pu, as shown in (13).

$$50NP > \frac{\max(I_{unbal}, I_{min})}{CTRN \cdot I_{NOM_CTRN}} \quad (13)$$

The following subsections explain how to calculate I_{unbal} and I_{min} .

1) Maximum Unbalance Current (I_{unbal})

For solidly grounded transformers, it is important that the 50NP pickup be set above the maximum unbalance current (system unbalance) which can circulate due to line asymmetries, load unbalance, unbalanced 3-phase faults, etc. A minimum setting of 10 percent of a bolted 3-phase fault can be used. This is similar to how the zero-sequence directional elements are secured for these same system conditions as explained in [14]. The higher pickup should not affect the dependability of the element since IN is significant for faults close to the neutral as well as faults along the winding (as seen in Fig. 5).

For low-impedance grounded transformers, the unbalance current does not need to be calculated as it is limited by the NGR and is typically much lower than I_{min} .

2) Minimum Current for Measurement Accuracy (I_{min})

For the REF element to perform reliably, the relay must receive IN and IG currents that are large enough for accurate magnitude and angle measurements (at least 5 percent of the CT rated current). Often on low-impedance grounded transformers, the ground CT has a much lower ratio than the zone boundary CTs. This means that the same ground current will be much smaller in secondary amperes when measured by the zone boundary CTs (IG) compared to the ground CT (IN). To ensure accuracy, the pickup level of the REF element should be set so that the element can only operate when at least 5 percent of nominal current exists on both the IN and IG inputs.

The following equations can be used to calculate the minimum current requirement for the ground CT input (14) and the terminal CT input (15) in primary amperes.

$$I_{N_{min}} = 0.05 \cdot I_{NOM_CTRN} \cdot CTRN \quad (14)$$

$$I_{G_{min}} = 0.05 \cdot I_{NOM_CTR} \cdot CTR \quad (15)$$

where:

I_{NOM_CTRN} is the nominal current of the ground CT (typically 5 A or 1 A).

$CTRN$ is the CT ratio of the ground CT.

I_{NOM_CTR} is the nominal current of the zone boundary CTs (typically 5 A or 1 A).

CTR is the CT ratio of the zone boundary CTs.

The measurement accuracy requirement is the highest value resulting from (14) and (15), as shown in (16). On low-impedance grounded transformers, $I_{G_{min}}$ will typically be greater than $I_{N_{min}}$ and will be the limiting factor in how low 50NP can be set.

$$I_{min} = \max(I_{N_{min}}, I_{G_{min}}) \quad (16)$$

C. Calculating Winding Coverage

1) Solidly Grounded Transformers

The REF element provides the best coverage on solidly grounded transformers because there is always a large amount

of IN current available regardless of the fault location (see Fig. 5). Even though the REF element is only required to detect ground faults near the bottom of the winding in these transformers, its coverage will often extend to other parts of the winding and overlap with the 87R element. Because of this, calculating REF element coverage on solidly grounded systems is usually not required.

2) Low-Impedance Grounded Transformers

The REF element provides less coverage on low-impedance grounded transformers for two reasons. First, the IN current is small for fault locations close to the neutral (see Fig. 4). Second, the 50NP setting cannot be set too low due to the influence of the terminal CT ratios on the minimum current requirement given by (16).

The winding coverage provided by the REF element on low-impedance grounded transformers can be calculated using (17) [16] and is derived in Appendix B.

$$REF_C \% = 100 \left(1 - \frac{50NP \cdot R_n \cdot CTRN \cdot I_{NOM_CTRN} \cdot \sqrt{3}}{kV_{LL} \cdot 1,000} \right) \quad (17)$$

To complement the REF element and provide additional winding coverage, a time-delayed ground overcurrent element operating on IN should be used. Since this overcurrent element typically uses only a single low-ratio ground CT, its pickup setting is not limited by the terminal CT ratios in (16). Instead, its pickup setting is limited by (14), which allows the overcurrent element to be set more sensitively than the REF element. The element's pickup and time delay should be set above any downstream ground overcurrent elements and below the rating of the NGR (with margins).

D. Enhancing the REF Element for Low-Impedance Grounded Systems

The security and dependability of the REF element is challenged when applied to low-impedance grounded transformers. There are two issues that are of concern: external phase-to-phase-to-ground (PPG) faults and systems with high charging current. These two challenges as well as solutions are described below.

1) Security Issue: External PPG Faults

For solidly grounded systems, the REF element is inherently secure against saturation of both the terminal and ground CTs. If the zone boundary CTs saturate during external phase-to-phase or three-phase faults and create a fictitious residual current (IG), the REF element will not misoperate. This is because IG current is only used for supervising the REF tripping decision and cannot cause the element to operate without the existence of IN. IN does not flow on the system for these fault types, and it is not possible for fictitious IN to exist either. This is because IN is measured by a single CT instead of a residual connection. In the case that an external three-phase fault is unbalanced and causes IN to flow in the system, setting the pickup of the REF element using the recommendations in Section IV.B will keep the element secure.

If either the terminal or ground CTs saturate during an external ground fault, IN is present and the element waits for

permission from the angle check before operating. Field events have shown that the current from a saturated CT has an angle error not greater than 75 degrees [17] [18]. As a result, when the angle check is performed, the difference between I_N and I_G changes from the ideal value of 180 degrees to some value greater than 105 degrees, which still lands in the external fault region of Fig. 9 and the element will not operate.

For low-impedance grounded systems, saturation of the zone boundary CTs during external three-phase and phase-to-phase faults does not affect the security of the REF element as explained previously and the REF tripping bit, REF_50N, will not assert.

Saturation of the zone boundary CTs is not a concern for external single-phase-to-ground faults since the ground and phase currents are limited by the NGR.

Saturation of the zone boundary CTs, however, is a concern during external PPG faults. For an external PPG fault, I_N does exist and the REF tripping element is only waiting for the presence of I_G and a permissive output from the angle check comparator to assert. The magnitudes of I_N and I_G currents are limited by the NGR, but the phase currents can be quite large since the negative-sequence network (which is in parallel with the zero-sequence network) has an impedance that is orders of magnitude smaller than that of the zero-sequence network (dominated by the NGR). If the zone boundary CTs saturate due to the high phase currents, the resulting error current can overwhelm the small (but true) I_G current and can cause the angle check to yield incorrect results.

This is why it is important that a REF element applied on a low-impedance grounded transformer include some security enhancement against CT saturation during external PPG faults. This protection can be built into relay firmware or programmed by the user, which is shown as follows.

a) Firmware Solution

Reference [16] describes two methods that work together to secure the REF element during external PPG faults on low-impedance grounded transformers, both of which are shown in Fig. 10. The output of this logic is REF_HSM. NOT REF_HSM can be used to block the REF element through the REF_TC input in Fig. 7.

The first method makes use of the fact that CTs do not saturate instantaneously. As a result, when an external fault occurs, the REF element will see it as external before the zone boundary CTs have had time to saturate and change that decision. Logic similar to REF_DIR asserts logic REF_EXT in Fig. 10, the only difference being that the angle check is now looking for faults in the external fault region of Fig. 9. The initial external decision (REF_EXT) asserts REF_HSM and can be used to block the REF element for one second, giving the zone boundary CTs enough time to come out of saturation. Note that this method requires the CTs to perform well for the first 1/8 of a cycle after fault inception. This is typically not an issue but can be verified by using the CT selection calculations given in [16].

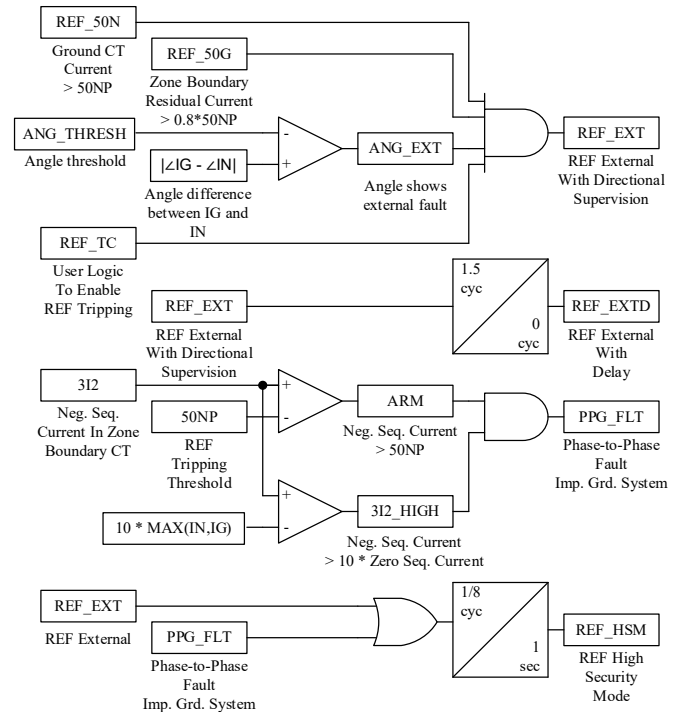

Fig. 10 REF high-security mode logic.

The second method to secure the REF element is to simply block the element for PPG faults on low-impedance grounded systems, regardless of whether the fault is internal or external. Blocking the REF element for this fault type does not create a blind spot in the protection scheme because the 87R element will operate for any internal PPG faults. A PPG fault on low-impedance grounded systems will always have more negative-sequence current than ground current because the NGR limits the ground current magnitude. PPG_FLT asserts when the negative-sequence current is above the 50NP threshold and is an order of magnitude greater than the I_N or I_G current, as shown in Fig. 10. Similar to the previous method, this decision is made during the first 1/8 of a cycle after fault inception and held for one second.

b) Custom Logic Solution

If the relay being applied does not have the built-in high-security logic shown in Fig. 10, a simple negative-sequence overcurrent (50Q) element can be used to detect a PPG fault. The 50Q element can be programmed into the REF_TC input to block the REF element from operating. If the relay does not have a REF_TC input, the 50Q supervision can always be added before the relay's final trip decision, as shown in Fig. 11. The 50Q element pickup can be set at two times the maximum I_G current (limited by the NGR) for a bolted single-phase-to-ground fault at the terminal. The firmware solution in Fig. 10 uses a ten times margin, but a two times margin over the calculated maximum ground fault current limited by the NGR is adequate.

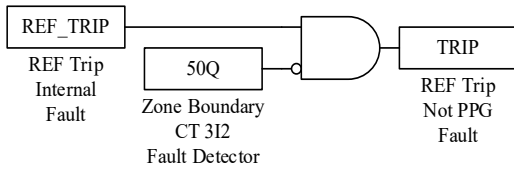

Fig. 11 Adding 50Q supervision for CT saturation on low-impedance grounded systems.

2) Dependability Issue: Systems With High Charging Current

The angle check performed by traditional REF elements can be challenged by low-impedance grounded cable distribution systems. Such systems include distributed generation with inverter-based resources and large collector systems, industrial plants, and data centers. These systems may have high-voltage cables with high zero-sequence capacitance to ground, resulting in high zero-sequence charging currents during single-phase-to-ground faults, for which the zero-sequence voltage is high due to the large voltage across the NGR. Reference [1] describes how, in these systems, the angle difference between IN and IG can be close to 90 degrees for internal faults. This poses a dependability issue when the 90-degree angle falls into the “dead zone” and prevents the REF element from operating.

Solutions to improve dependability of the REF element when applied to low-impedance grounded cable distribution systems can be built into firmware or custom built by the user. These solutions are described as follows.

a) Firmware Solution

Some relays expand the internal fault region to ± 105 degrees, as shown in Fig. 12 [14]. This allows for faults that previously fell into the “dead zone” to now fall into the internal fault region.

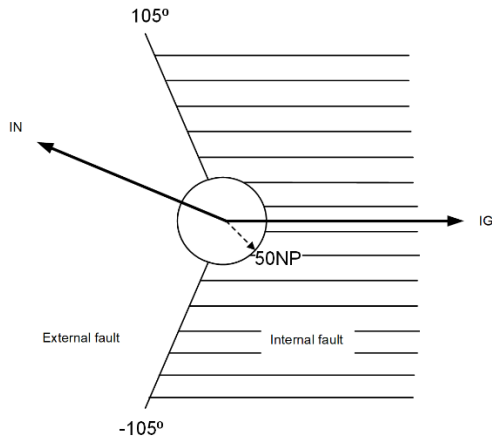

Fig. 12 Angle check in a REF element designed for low-impedance grounded systems.

b) Custom Logic Solution

If the applied relay uses the operating characteristic in Fig. 9 instead of Fig. 12, it is possible to add the same dependability using custom logic. Instead of only tripping when the angle falls in the internal fault region, the element can be made to trip when the angle does not fall in the external fault region, therefore including faults that land in the “dead zone” around ± 90 degrees.

To implement this logic, the relay must provide indication of when the fault lands in the external fault region of Fig. 9. This indication may be provided instantaneously (REF_EXT in Fig. 10) or after the built-in time delay (REF_EXTD in Fig. 10).

If the relay provides REF_EXT [15], the logic necessary to add dependability is shown in Fig. 13. With this logic, if REF_TRIP asserts (due to REF_DIR or REF_NDIR), the REF element operates as usual. If the fault lands in the “dead zone,” REF_TRIP will not assert. Another path that uses NOT REF_EXT allows tripping for faults in the dead zone of the characteristic.

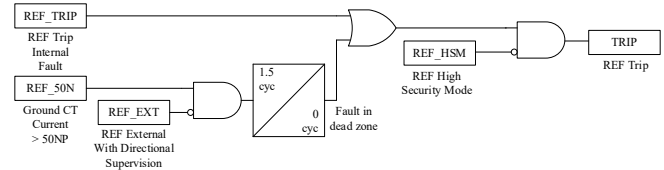

Fig. 13 Using logic to increase the dependability of the traditional REF element when the relay provides REF_EXT.

If the relay only provides the external decision after a built-in time delay (REF_EXTD) [13], the logic necessary to add dependability is shown in Fig. 14. With this logic, if REF_TRIP asserts (due to REF_DIR or REF_NDIR), the REF element operates as usual and trips after 1.5 cycles. If the fault lands in the “dead zone,” REF_TRIP will not assert. REF_EXTD will remain deasserted, allowing REF_50N to start the 2-cycle timer and trip the transformer. If the fault lands in the external fault region, REF_EXTD will be initially deasserted, allowing REF_50N to start the 2-cycle timer. Once REF_EXTD asserts (after 1.5 cycles), it will stop the timer and block the relay from tripping. For this logic to work properly, it is critical that the 2-cycle timer be longer than the time delay between REF_EXT and REF_EXTD.

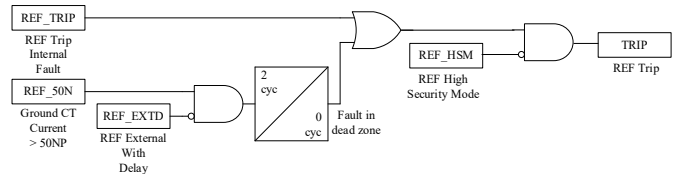

Fig. 14 Using logic to increase the dependability of the traditional REF element when the relay provides REF_EXTD.

E. Applying REF on Three-Phase Transformer Banks Made of Single-Phase Transformers

Large and/or critical three-phase transformer banks are sometimes made up of three single-phase transformers. This may be done to reduce the size of the equipment to facilitate its transportation to the site. It may also be done to enhance resiliency for a critical application by having a spare single-phase transformer for fast substitution in case of a failure. In these applications, the wye connection is not made inside the transformer but outside the transformer using one of two possible methods.

The first method is the most common and forms the wye connection by connecting one end of each winding directly to ground. In these installations, the current-polarized directional REF element should not be used. This is because a single

ground CT can no longer be used to measure the I_N current. Instead, a CT must be installed on each grounded bushing and the three CTs must be summed to derive I_N . Because I_N is no longer a measurement by a single CT but rather a residual measurement from summing three CT currents, this violates the fundamental principle of a current-polarized directional REF element. (That is, the tripping decision is made by the REF_50N comparator using a signal that is immune from fictitious ground current.)

For such installations, it is preferred to use a phase-segregated REF scheme as described in [19]. Each phase winding has its own protection zone. The current entering the protection zone is measured by the CT on the grounded bushing of that phase. The current leaving the protection zone is measured by the zone boundary CT of that phase. During an internal fault, the two currents will not be equal and the scheme will operate. This scheme is also sometimes called a Kirchhoff's current law winding differential [11].

The second method forms the wye connection by connecting one end of each bushing to a neutral bus and then grounding the neutral bus. If the neutral bus can be grounded through a single connection passing through the window of a CT on the ground lead, then the current-polarized REF element can be used, and the user does not have to do anything special.

V. CASE STUDY: WHEN 87R FAILED, REF WOULD HAVE PREVAILED

As explained in Section III, the 87R element cannot detect all ground faults in the wye side of a transformer protection zone. This section will show one of several events we have seen where the 87R element did not operate for an internal ground fault on a low-impedance grounded transformer. Next, it will show how the 87R element's lack of sensitivity could have been identified at the time of settings development. Finally, it will demonstrate how enabling REF would have allowed the relay to detect this fault faster.

A. Analyzing 87R Element Response to an Around Fault

The fault occurred at an industrial facility on a 20 MVA, 24.9/4.16 kV, DABY step-down transformer—see Fig. 15 for a simplified three-line diagram. The transformer was grounded through a 2,400 V/400 A/10 seconds NGR. The specifications indicate that when 2,400 V is applied across the NGR terminals, 400 A of current will flow through it, making R_n equal to 6 Ω . The NGR can withstand 400 A for 10 seconds, after which it will overheat and sustain damage.

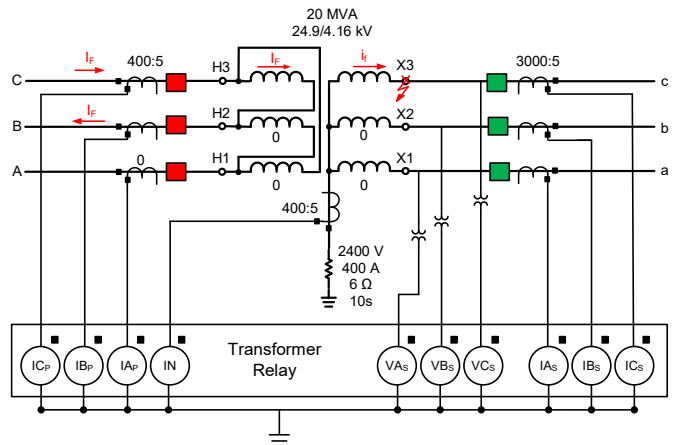

Fig. 15 Three-line diagram for case study transformer.

An 87R element protects the transformer, and its assertion opens both the high- and low-side breakers. The harmonic restraint is enabled to keep the element secure during energization. The settings relevant to this event are summarized in Table I. Note that settings with the subscript "P" are for the primary side, and settings with the subscript "S" are for the secondary side. In addition, a 51N element provides backup protection for all low-side system ground faults and its assertion opens the low-side breaker.

TABLE I
RELAY SETTINGS FOR THE CASE STUDY

Setting	Value
O87P	0.3 pu
SLP	25%
TAP _p	5.79 A
TAP _s	4.62 A
PCT2	15% ($k_2 = 6.67$)
CTR _p	80
CTR _s	600
CTR _N	80
I_{NOM_CTR}	5 A
$I_{NOM_CTR\sub N}$	5 A

On a particularly eventful day, a CG fault occurred during energization of the transformer with the low-side breaker open. The fault was on the wye-side X3 bushing and was caused by a connection error, which accidentally grounded the C-phase conductor.

Fig. 16 shows the filtered event report captured by the transformer relay during the fault. At the inception of the fault (Part 1), we expect the primary delta-side currents (I_{A_p} , I_{B_p} , and I_{C_p}) to show a BC fault signature (I_{B_p} and I_{C_p} currents equal and 180 degrees out of phase). This is because a CG fault on the wye side of a DABY transformer looks like a BC fault on the delta side (as described in [20] and shown in Fig. 15). Instead, the magnetizing current that occurs during energization dominates the fault current and gives us the waveforms seen in Part 1 of Fig. 16 after passing through the relay filter. Because the fault signature is dominated by inrush, it is difficult to determine if a fault has occurred solely from the delta-side currents.

However, the presence of ~ 400 A of ground current (I_N) indicates that there is a ground fault on the wye side of the transformer. Furthermore, the measured C-phase voltage on the secondary wye side of the transformer (V_{C_s}) is 0, indicating a close-in CG fault. The phase-to-ground voltages of the healthy phases (V_{A_s} and V_{B_s}) are higher than the nominal voltage due to the additional voltage drop across the NGR ($\sim 2,400$ V) during the ground fault. The phase-to-ground voltage is equal to the summation of the phase-to-neutral voltage and the neutral-to-ground voltage across the NGR.

According to (2), for the 87R element to assert for this internal fault, the operating current (IOP) must be greater than O87P and HR_THRESH for that phase. In Fig. 16, the operating currents for A- and C-phases (a combination of inrush and fault current) are initially above the O87P threshold. As time progresses, the operating current on these two phases decreases, indicating that one of the contributors to the operating current is getting smaller. Since we do not expect the fault current to change during this time, the contribution due to inrush must be decreasing. Eventually, the operating currents fall below the O87P threshold. Since the operating currents with inrush are below the O87P threshold, that means the operating currents due to the fault (with no inrush) would be even further below the O87P threshold. This proves the lack of sensitivity of the 87R element for this type of fault.

Although the operating currents did initially go above the O87P threshold for A- and C-phases due to inrush, 87R never

asserted because the currents never went above HR_THRESH. This is because the relay was using harmonic restraint and increased the restraint threshold by the measured second harmonic operating current multiplied by a scaling factor of k^2 . The increased threshold made it even more difficult for the 87R element to trip for this type of fault. This is why in Appendix A.C., the check to see if 87R will operate during inrush conditions is simplified to $IOP > HR_THRESH$.

Part 2 of Fig. 16 shows the waveforms captured by the relay a few seconds into the fault. By this time, the inrush current has completely decayed out and the delta-side currents show the expected BC fault signature. Because there are no harmonics, HR_THRESH is lower than what it was in Part 1, allowing the operating currents on B- and C-phases to plot above HR_THRESH. The limiting factor for 87R operation becomes the O87P threshold. The operating currents on B- and C-phases are now purely due to the fault and are still below the O87P threshold, preventing the 87R element from operating. This is why in Appendix A.A., the check to see if 87R will operate during no load conditions is simplified to $IOP > O87P$.

Part 3 of Fig. 16 shows the waveforms captured by the relay 25.042 seconds into the fault. By this time, I_N had far exceeded the thermal limit of the NGR (400 A for 10 seconds) and caused it to fail as a short circuit to ground. This turned the low-impedance grounded transformer into a solidly grounded transformer. As a result, I_N dramatically increased from 400 A to 12,000 A while the healthy phase voltages returned to nominal values.

When the NGR failed, the magnitudes of the B- and C- phase currents on the delta side also increased (from 80 A to 1,500 A). This caused the calculated operating current on B- and C-phases to increase and overcome the O87P threshold. As explained previously for Part 2, the operating current will always be above HR_THRESH for this condition. As a result, the 87R element for the B- and C-phases asserted after a built-in security delay of 1.25 cycles and tripped the high-side breaker.

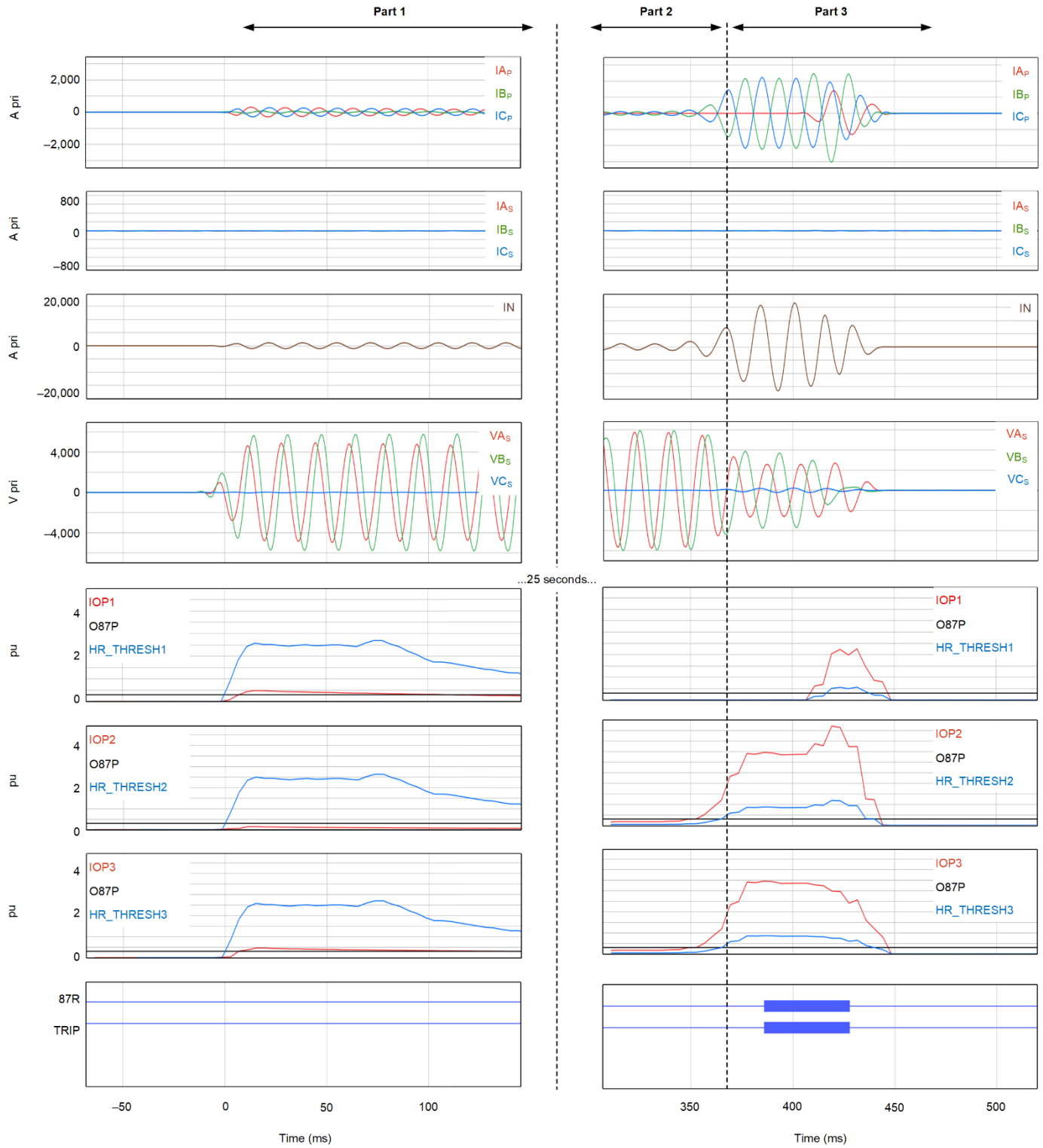

Fig. 16 Initially, 87R was unable to detect the 400 A internal CG fault. 25 seconds later, 87R operated when the NGR shorted and increased the ground current to 12,000 A.

B. Calculating 87R Coverage

The 87R element did not have any trouble detecting a fault at the terminal of the transformer when the transformer was solidly grounded (NGR shorted). It did, however, have trouble detecting the same fault when the transformer was low-impedance grounded through the NGR (limiting the ground

current to 400 A). Unfortunately, this lack of 87R element sensitivity was discovered after an actual fault occurred, damaged the NGR, and subjected the transformer windings to a significant through fault. All of this could have been avoided by discovering the lack of 87R element sensitivity when first developing the relay settings.

We calculated the 87R element winding coverage using the no load equation in (12). The result of this calculation is shown in Table II. We can see that $87R_C$ percent has a negative value, which means that the 87R element provides no coverage for ground faults anywhere on the wye side of the transformer protection zone. This result matches what was observed in the field event. We also calculated $87R_C$ percent for rated load and energization conditions using the equations in Table III. We used 40 percent as the value of IOP_{2H} based on the initial value measured during energization. These calculations show how the winding coverage gets even worse under rated load and energization conditions. These calculations prove that enabling REF is absolutely necessary on this low-impedance grounded transformer.

TABLE II
87R WINDING COVERAGE CHECKS FOR CASE STUDY

Condition	Winding Coverage Check
No Load	$87R_C \% = 100 \left(1 - \sqrt{\frac{\sqrt{3} \cdot 0.87P \cdot CTR_p \cdot TAP_p \cdot R_n}{1,000 \cdot kV_{LL} \cdot TR}} \right)$
	$87R_C \% = 100 \left(1 - \sqrt{\frac{\sqrt{3} \cdot 0.3 \cdot 80 \cdot 5.79 \cdot 6}{1,000 \cdot 4.16 \cdot \frac{4.16}{\sqrt{3} \cdot 24.9}}} \right)$
	$87R_C \% = -90\%$
Rated Load	$87R_C \% = 100 \cdot \left(1 - \sqrt{\frac{\sqrt{3} \cdot \frac{SLP}{50} \cdot CTR_p \cdot TAP_p \cdot R_n}{1,000 \cdot kV_{LL} \cdot TR \left(1 - \frac{SLP}{100} \right)}} \right)$
	$87R_C \% = 100 \cdot \left(1 - \sqrt{\frac{\sqrt{3} \cdot \frac{25}{50} \cdot 80 \cdot 5.79 \cdot 6}{1,000 \cdot 4.16 \cdot \frac{4.16}{\sqrt{3} \cdot 24.9} \left(1 - \frac{25}{100} \right)}} \right)$
	$87R_C \% = -183\%$
Energization	$87R_C \% = 100 \cdot \left(1 - \sqrt{\frac{\sqrt{3} \cdot k_2 \cdot IOP_{2H} \cdot CTR_p \cdot TAP_p \cdot R_n}{1,000 \cdot kV_{LL} \cdot TR \left(1 - \frac{SLP}{100} \right)}} \right)$
	$87R_C \% = 100 \cdot \left(1 - \sqrt{\frac{\sqrt{3} \cdot 6.67 \cdot 0.4 \cdot 80 \cdot 5.79 \cdot 6}{1,000 \cdot 4.16 \cdot \frac{4.16}{\sqrt{3} \cdot 24.9} \left(1 - \frac{25}{100} \right)}} \right)$
	$87R_C \% = -554\%$

C. Calculating REF Coverage

The equations in Section IV can be used to predict how the REF element would have performed for this event had it been enabled. The 50NP pickup setting would be calculated using (13). Because this is a low-impedance grounded transformer, I_{unbal} can be neglected and I_{min} is calculated using (16) and solved in (18).

$$\begin{aligned}
 I_{min} &= \max(I_{N_{min}}, I_{G_{min}}) \\
 I_{N_{min}} &= 0.05 \cdot I_{NOM_CTRN} \cdot CTRN = 0.05 \cdot 5 \cdot 80 = 20 \text{ A} \\
 I_{G_{min}} &= 0.05 \cdot I_{NOM_CTR} \cdot CTR = 0.05 \cdot 5 \cdot 600 = 150 \text{ A}
 \end{aligned} \tag{18}$$

This results in $I_{min} = 150 \text{ A}$, and $50NP = 0.4 \text{ pu}$, as shown in (19).

$$50NP > \frac{\max(I_{unbal}, I_{min})}{CTR_N \cdot I_{NOM_CTRN}} = \frac{150}{80 \cdot 5} = 0.375 \text{ pu} \tag{19}$$

Equation (17) can be used to calculate the winding coverage provided by the REF element as (20).

$$\begin{aligned}
 REF_C \% &= 100 \left(1 - \frac{50NP \cdot R_n \cdot CTRN \cdot I_{NOM_CTRN} \cdot \sqrt{3}}{kV_{LL} \cdot 1,000} \right) \\
 REF_C \% &= 100 \left(1 - \frac{0.4 \cdot 6 \cdot 80 \cdot 5 \cdot \sqrt{3}}{4.16 \cdot 1,000} \right) = 60\%
 \end{aligned} \tag{20}$$

This means that the REF element would have been able to protect 60 percent of the winding starting from the terminal and would have been able to easily detect this fault. This is in stark contrast to the complete lack of ground fault coverage provided by the 87R element.

D. Confirming Relay Response With REF Enabled

To confirm that the REF element response to this fault would match our expectations, we enabled the element in a transformer relay with a 50NP pickup setting of 0.4 pu and replayed the fault to the relay. Fig. 17 shows the relay response to the fault with REF enabled. We can see that when the fault occurred, REF_50N picked up and enabled the element. Because the wye-side breaker was open and the zone boundary CTs did not measure any IG current (REF_50G was deasserted), and the REF_HSM supervision was satisfied (REF_TC was asserted), the non-directional path of the REF logic asserted (REF_NDIR). 1.5 cycles later, REF_TRIP asserted to declare an internal fault and the relay tripped.

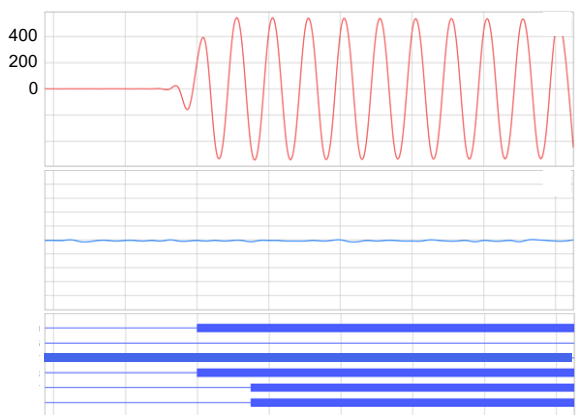

Fig. 17 REF element detects ground fault and asserts within 1.5 cycles.

Based on this analysis, the engineers at the industrial facility decided to enable the REF element in the transformer relay. This was a simple addition that required no additional wiring, since they already had a ground CT on the wye winding that was wired to the relay for 51N protection.

E. Additional Recommendations

In addition to enabling REF, the following two additional recommendations could improve the overall protection scheme of the transformer.

1) Lower O87P for Increased Sensitivity

One recommendation for this case study is to lower the O87P setting to a value not less than $(0.5 / \text{minimum (TAP}_P, \text{TAP}_S))$, as explained in [21]. The lower setting increases the sensitivity of the 87R element for partial-winding faults. Following this guidance would allow the engineer to lower the O87P setting in this case study from 0.3 to 0.11. Substituting this reduced setting value of O87P into (12) yields $87R_C$ percent equal to -20 percent, which means that the 87R element would still not see ground faults anywhere on the secondary side of the transformer. Decreasing the O87P setting, however, is still recommended because it will increase sensitivity for other fault types.

2) Allow 51N Element to Open the Source-Side Breaker

Another recommendation for this case study is to use the 51N element to also open the transformer source-side breaker. This allows the element to not only provide system backup protection for ground faults but also complement the REF element, because it can typically be set to cover a greater portion of the windings near the neutral (pickup set more sensitively than the REF 50NP pickup, due to the lower ratio of the ground CT) but with a time delay. In this example, REF was not enabled, but the 51N element would have cleared this fault in 270 cycles had it been allowed to open the source-side breaker. This would have prevented the catastrophic failure of the NGR and the transformer from being subjected to high through-fault currents.

VI. COMMISSIONING A REF INSTALLATION

The most common reason for REF element misoperations is wiring errors. A large utility in the eastern United States reported 11 REF element misoperations over the course of 6 years due to incorrect wiring [22]. Hearing about these misoperations can make engineers nervous about enabling REF in their transformer relays. Fortunately, all that is required to ensure correct operation of the REF element is proper testing. This section will show how to commission a REF element correctly to ensure dependability and security.

Wiring errors that can affect a REF element are:

1. Wye-side zone boundary CTs mistakenly connected in delta instead of wye.
2. Incorrect CT ratio or tap on wye-side zone boundary CTs.
3. Incorrect CT ratio or tap on ground CT.
4. Wye-side zone boundary CTs and the ground CT not connected with differential polarities. It is also possible that the CTs on the primary system are connected with differential polarities, but either the terminal or ground CT secondary wiring is swapped at the relay terminals.

These errors can be detected using either primary or secondary current injection. Reference [23] describes the circumstances under which errors can be missed using secondary injection. For this reason, primary injection testing is preferred when commissioning transformers. Errors 1 and 2 (at the beginning of the section) can be easily found with standard 87R commissioning processes. Errors 3 and 4 are more difficult to detect because the test requires current to circulate through the ground connection of the wye winding.

Performing primary injection testing requires proper planning. The transformer must be isolated from the rest of the system for safety. Other relays on the system that use ground current for protection must be disabled, otherwise, they may operate when the test currents are injected. If these requirements cannot be met, or the transformer is already in service, it may be possible to perform an “offline commissioning check” using an event report after a ground fault has occurred. This section will discuss how both methods can be used to verify the installation of a current-polarized directional overcurrent REF element.

A. Primary Current Injection

The primary current injection is performed differently, depending on the location of the terminal and ground CTs [24] as well as access to test equipment.

1) CTs Inside the Transformer

It is most common for terminal or ground CTs to be located inside the transformer (the CTs are located at the base of the bushings or embedded inside the transformer). In this case, primary current injection can be performed using the connections shown in Fig. 18.

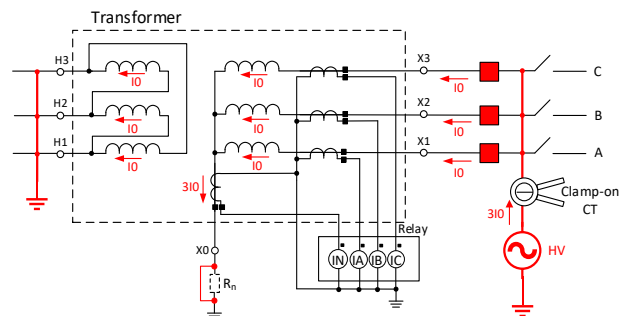

Fig. 18 Connections required for primary injection when terminal or ground CTs are located inside the transformer.

Connect a single-phase alternating current (ac) high-voltage source to all three phases external to the wye-side zone boundary CTs. Short all three terminals on the other side of the transformer to ground to reduce the impedance seen by the test source. Close the wye-side breaker to allow zero-sequence current to flow through the circuit. These connections ensure that the zone boundary and ground CTs measure the zero-sequence current injected by the source.

The minimum current required for the test is given by (21).

$$I_{\text{source}} > 0.25 \cdot \text{CTR}_P \quad (21)$$

The minimum voltage and VA rating of the source are given by (22) and (23), respectively.

$$V_{\text{source(LN)}} = Z_{T(\text{pu})} \cdot \frac{kV_{LL}^2}{\text{MVA}} \cdot 0.25 \cdot \text{CTR}_p \quad (22)$$

$$\text{VA}_{\text{source}} = 0.1875 \cdot Z_{T(\text{pu})} \cdot \frac{kV_{LL}^2}{\text{MVA}} \cdot \text{CTR}_p^2 \quad (23)$$

The previous equations are derived in Appendix C. Note that the existence of an NGR will limit the ground current and unnecessarily increase the required VA rating of the source, so it must be temporarily shorted out during the primary injection test. Be sure to remove the short after the test is complete.

Confirm that the necessary source current from (21) is flowing by using a clamp-on CT, as shown in Fig. 18. Next, verify the magnitude of the ground CT measurement by comparing the magnitude of IN reported by the relay metering to that measured by the clamp-on CT. The magnitudes should be equal. Verify the polarity of the ground CT with respect to the zone boundary CTs by comparing the angle of IN to the angle of IG reported by the relay metering. The angles should be 180 degrees out of phase.

One benefit of injecting current on all three phases is that it also allows us to discover issues with the zone boundary CTs (e.g., Errors 1 and 2 at the beginning of this section). To do this, compare the magnitude of the phase currents reported by the relay metering to that measured by the clamp-on CT. The magnitude of the phase currents should be a third of the current measured by the clamp-on CT.

This test proves the correct installation of the ground and zone boundary CTs. If desired, additional tests can be performed to simulate internal and external faults and verify the response of the REF element. For more information on primary injection testing, see [25].

2) CTs Outside the Transformer

If the terminal and ground CTs are all located outside the transformer terminals (the zone boundary CTs are post CTs or breaker CTs, and the ground CT is between the X0 bushing and ground), primary current injection can be performed using the connections shown in Fig. 19. Here, jumper cables are used to short all three phases of the terminal side of the wye winding to the X0 bushing. This connection bypasses the transformer impedance and allows the use of a test source with a lower voltage and VA rating. The required minimum current can be calculated using (21). The source ratings can be calculated using (22) and (23), but replace the pu transformer impedance with the pu impedance of the leads and buswork between the low-voltage source and ground. The rest of the test procedure is the same as described in the previous subsection for CTs inside the transformer.

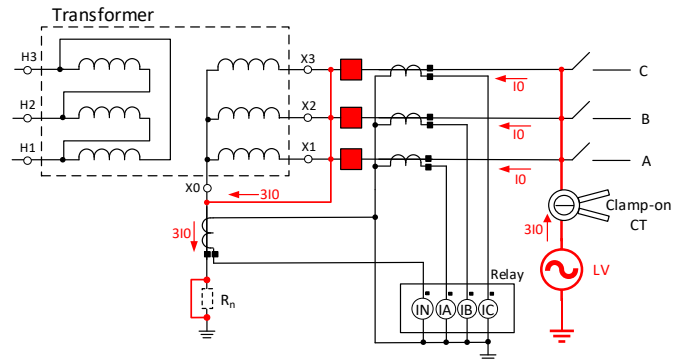

Fig. 19 Connections required for primary injection when terminal and ground CTs are located outside the transformer.

3) Other Tests

Although ac primary current injection testing is recommended when commissioning a REF element, gaining access to the required test equipment may sometimes prove challenging. In these cases, tests using direct current (dc) primary injection can be performed. The dc kick test described in [23] as well as the simple polarity test described in [26] are two examples of these types of tests. Although these tests are simpler to perform, they can only detect polarity errors. Errors 1, 2, and 3 will remain undetected.

B. Offline Commissioning Check

An event report after a ground fault can be used to perform an “offline commissioning check” to validate the polarity and magnitude of the ground CT measurement.

An external ground fault will allow verification of both the magnitude and polarity of the ground CT measurement with respect to the zone boundary CTs. Plot the IN and IG currents in the event report and verify that they are equal in magnitude and 180 degrees out of phase.

An internal ground fault will only allow verification of the polarity of the ground CT with respect to the zone boundary CTs. This verification requires a source on the wye side. Plot the IN and IG currents in the event report and verify that they have similar phase angles. Since the two currents will have different magnitudes, this fault cannot be used to verify the magnitude of the ground CT measurement.

The offline commissioning checks described previously cannot be used if severe CT saturation is observed in the event report. Refer to [27] to learn how to detect CT saturation in event reports. The internal ground fault check cannot be used to verify polarity on low-impedance grounded cable distribution systems since IN and IG on the primary system may not have similar phase angles during internal ground faults.

VII. CONCLUSION

Many protection engineers overlook the importance of REF and rely on the 87R element to detect all faults in transformers. Unfortunately, the 87R element may have trouble detecting ground faults, depending on the type of transformer grounding and the distance of the fault from the neutral on the wye winding.

For solidly grounded transformers, ground faults very close to the neutral produce low-magnitude phase currents, which may not be enough to cause an 87R element operation. For these faults, however, the high-magnitude ground current circulating through the shorted turns can damage the transformer if allowed to persist. Estimating the 87R element winding coverage can be done using software capable of adequately simulating winding-to-ground faults.

For low-impedance grounded transformers, ground faults anywhere on the wye side of the transformer zone produce low-magnitude phase currents, which may not be enough to cause an 87R element operation. Calculating the 87R element winding coverage for a delta-wye transformer can be done using (12).

Although the faults discussed previously can have low-magnitude phase currents, the corresponding ground currents will be higher. The REF element uses this ground current to provide greater winding coverage for ground faults and can be used to complement the 87R element. Its coverage is typically the best on solidly grounded transformers, since the ground current is significant regardless of the location of the fault. For low-impedance grounded transformers, the REF element significantly improves coverage compared to the 87R element but may struggle to detect faults closer to the neutral. For these transformers, (17) can be used to calculate the element's winding coverage. A time-delayed neutral overcurrent element (with a sensitive pickup) can be used to provide additional winding coverage.

The REF element has been available in transformer relays for decades but is not commonly applied. This could be due to engineers not understanding the purpose and importance of this element for both low-impedance and solidly grounded transformers. It could also be due to the perception that the element is too complicated or prone to misoperations due to wiring errors. To dispel these misconceptions, this paper explains why REF is required, how simple and secure the principle actually is, how to set it, and how to commission it to avoid misoperations.

To give an example of how a transformer can be left vulnerable to ground faults if REF is not enabled, the paper presents a field event from an industrial facility. In this event, the 87R element failed to detect a ground fault on the wye terminal of a low-impedance grounded transformer, which resulted in significant damage to power system equipment. Engineers at the facility never considered a ground fault at the terminal to be a challenge to the 87R element until one occurred and exposed the element's lack of sensitivity. We used (12) to

prove that the 87R element provided no coverage for ground faults in this case. In contrast, (17) showed that the REF element would have detected this fault and any other fault in the top 60 percent of the winding.

The field event presented in this paper is not a special case. We have seen several similar events where the 87R element failed to detect a ground fault on the wye winding of a low-impedance grounded transformer. To improve the dependability, sensitivity, and speed of ground fault protection for all transformers, we recommend always saying "YES" to REF.

VIII. APPENDIX A: DERIVING 87R WINDING COVERAGE FOR DELTA-WYE LOW-IMPEDANCE GROUNDED TRANSFORMERS

This appendix derives equations that use the 87R element settings to calculate how much of the wye winding is protected by the element for a ground fault. These checks are derived for a delta-wye low-impedance grounded transformer with the source on the delta side and load on the wye side. We assume that IOP and IRT are calculated using the equations shown in Fig. 1 and that the relay is using the 87R characteristic shown in Fig. 2.

During a ground fault on the wye winding of the transformer, placed at a distance x pu from the neutral, the current on the primary side (I_{p_x}) is given by (11), where I_{n100} is given by (8).

For a three-phase delta-wye transformer, the TR is given by (24).

$$TR = \frac{V_S}{\sqrt{3} \cdot V_P} \quad (24)$$

where:

V_S is the rated secondary wye-side line-to-line voltage.

V_P is the rated primary delta-side line-to-line voltage.

Using the equations in Fig. 1, we can now use I_{p_x} to calculate IOP and IRT currents. Because I_{p_x} is the current on the delta side, it will be divided by the delta-side tap setting but will not be compensated by an angle shift, as explained in [6]. The IOP and IRT currents are then used to calculate the 87R winding coverage for three different transformer conditions.

A. No Load

When the wye-side breaker is open, IOP and IRT in pu are equal to (25) and (26), respectively.

$$IOP = \frac{I_{p_x}}{CTR_p \cdot TAP_p} \quad (25)$$

$$IRT = \frac{I_{p_x}}{CTR_p \cdot TAP_p} \quad (26)$$

where:

CTR_p is the CT ratio on the primary delta winding.

TAP_p is the TAP setting for the primary delta winding.

Equation (1) can be used to determine whether the relay will operate or not. Because $IOP = IRT$ during no load conditions, IOP will always be greater than the SLP threshold (SLP_THRESH). Therefore, the check in (1) can be simplified to (27).

$$IOP > O87P \quad (27)$$

Substituting (25) into (27), we get (28).

$$\frac{I_{p_x}}{CTR_p \cdot TAP_p} > O87P \quad (28)$$

We can express the previous equation in terms of fault location by substituting (11) into (28). This gives (29).

$$\frac{x^2 \cdot I_{n100} \cdot TR}{CTR_p \cdot TAP_p} > O87P \quad (29)$$

Solving for x in (29), we get (30).

$$x > \sqrt{\frac{O87P \cdot CTR_p \cdot TAP_p}{I_{n100} \cdot TR}} \quad (30)$$

In percentage of the total wye winding, (30) equals (31).

$$x\% > 100 \cdot \sqrt{\frac{O87P \cdot CTR_p \cdot TAP_p}{I_{n100} \cdot TR}} \quad (31)$$

The previous equation means that the 87R element will operate for ground faults located above x percent of the winding, starting from the neutral. A more practical form of this equation is to calculate the percent of the winding protected by the 87R element, starting from the terminal. This equation can be written as (32).

$$87R_c\% = 100 - x\% \quad (32)$$

Substituting (31) into (32), we get (33).

$$87R_c\% = 100 \cdot \left(1 - \sqrt{\frac{O87P \cdot CTR_p \cdot TAP_p}{I_{n100} \cdot TR}} \right) \quad (33)$$

Substituting (8) for I_{n100} , we get (34).

$$87R_c\% = 100 \cdot \left(1 - \sqrt{\frac{\sqrt{3} \cdot O87P \cdot CTR_p \cdot TAP_p \cdot R_n}{1,000 \cdot kV_{LL} \cdot TR}} \right) \quad (34)$$

B. Rated Load

When the transformer is feeding rated load and a ground fault occurs on the wye winding, IOP remains the same as (25) but due to load flow, IRT is given by (35). The load current of 1 pu going through the transformer will be measured by both sets of CTs, increasing the total IRT by 2 pu.

$$IRT = \frac{I_{p_x}}{CTR_p \cdot TAP_p} + 2 \quad (35)$$

Equation (1) can be used to determine whether the relay will operate or not. Depending on where IRT lands on the restraint axis, this can be broken down into two checks.

1. If $IRT < O87P \cdot \frac{100}{SLP}$ the check for operation becomes (36) and winding coverage is given by (34).

$$IOP > O87P \quad (36)$$

With typical settings for $O87P$ and SLP , the rated load condition will most always result in a restraining quantity that is greater than $O87P \cdot \frac{100}{SLP}$ and this check will not be used.

2. If $IRT < O87P \cdot \frac{100}{SLP}$, the check for operation becomes (37).

$$IOP > \frac{SLP}{100} \cdot IRT \quad (37)$$

Substituting (25) and (35) into (37), we get (38).

$$\frac{I_{p_x}}{CTR_p \cdot TAP_p} > \frac{SLP}{100} \cdot \left(\frac{I_{p_x}}{CTR_p \cdot TAP_p} + 2 \right) \quad (38)$$

We can express the previous equation in terms of fault location by substituting (11) into (38), which gives (39).

$$\frac{x^2 \cdot I_{n100} \cdot TR}{CTR_p \cdot TAP_p} > \frac{SLP}{100} \cdot \left(\frac{x^2 \cdot I_{n100} \cdot TR}{CTR_p \cdot TAP_p} + 2 \right) \quad (39)$$

Solving for x , we get (40).

$$x > \sqrt{\frac{\frac{SLP}{50} \cdot CTR_p \cdot TAP_p}{I_{n100} \cdot TR \left(1 - \frac{SLP}{100} \right)}} \quad (40)$$

In percentage of the total wye winding, (40) equates to (41).

$$x\% > 100 \cdot \sqrt{\frac{\frac{SLP}{50} \cdot CTR_p \cdot TAP_p}{I_{n100} \cdot TR \left(1 - \frac{SLP}{100} \right)}} \quad (41)$$

Therefore, we can calculate the 87R element winding coverage for ground faults as (42).

$$87R_c\% = 100 \cdot \left(1 - \sqrt{\frac{\frac{SLP}{50} \cdot CTR_p \cdot TAP_p}{I_{n100} \cdot TR \left(1 - \frac{SLP}{100} \right)}} \right) \quad (42)$$

Substituting (8) for I_{n100} in (42), we get (43).

$$87R_c\% = 100 \cdot \left(1 - \sqrt{\frac{\sqrt{3} \cdot \frac{SLP}{50} \cdot CTR_p \cdot TAP_p \cdot R_n}{1,000 \cdot kV_{LL} \cdot TR \left(1 - \frac{SLP}{100} \right)}} \right) \quad (43)$$

C. Energization

When energizing a transformer with a ground fault on the wye winding, IOP and IRT currents remain the same as (25) and (26). If harmonic restraint is enabled, the restraint threshold will be boosted by a set amount of the second and fourth harmonics that exist in the inrush waveform. The equation for

operation is given by (2). Because IOP will typically exceed O87P during inrush, the check in (2) can be simplified to (44).

$$IOP > \frac{SLP}{100} \cdot IRT + k_2 \cdot IOP_{2H} + k_4 \cdot IOP_{4H} \quad (44)$$

Scaling constants k_2 and k_4 are typically set between 7 and 10, since user settings PCT2 and PCT4 are usually between 15 and 10, respectively. IOP_{2H} and IOP_{4H} can be determined using event reports recorded during transformer energization. IOP_{2H} is typically about 60 percent, while IOP_{4H} is typically much lower and can often be neglected [28].

Substituting (25) and (26) into (44) and neglecting the fourth harmonic, we get (45).

$$\frac{I_{p_x}}{CTR_p \cdot TAP_p} > \frac{SLP}{100} \cdot \frac{I_{p_x}}{CTR_p \cdot TAP_p} + k_2 \cdot IOP_{2H} \quad (45)$$

We can express the previous equation in terms of fault location by substituting (11) into (45). This gives (46).

$$\frac{x^2 \cdot I_{n100} \cdot TR}{CTR_p \cdot TAP_p} > \frac{SLP}{100} \cdot \frac{x^2 \cdot I_{n100} \cdot TR}{CTR_p \cdot TAP_p} + k_2 \cdot IOP_{2H} \quad (46)$$

Solving for x in (46), we get (47).

$$x > \sqrt{\frac{k_2 \cdot IOP_{2H} \cdot CTR_p \cdot TAP_p}{I_{n100} \cdot TR \left(1 - \frac{SLP}{100}\right)}} \quad (47)$$

In percentage of the total wye winding, (47) equates to (48).

$$x\% > 100 \cdot \sqrt{\frac{k_2 \cdot IOP_{2H} \cdot CTR_p \cdot TAP_p}{I_{n100} \cdot TR \left(1 - \frac{SLP}{100}\right)}} \quad (48)$$

Therefore, we can calculate the 87R element winding coverage for ground faults as (49).

$$87R_C\% = 100 \cdot \left(1 - \sqrt{\frac{k_2 \cdot IOP_{2H} \cdot CTR_p \cdot TAP_p}{I_{n100} \cdot TR \left(1 - \frac{SLP}{100}\right)}}\right) \quad (49)$$

Substituting (8) for I_{n100} , we get (50).

$$87R_C\% = 100 \cdot \left(1 - \sqrt{\frac{\sqrt{3} \cdot k_2 \cdot IOP_{2H} \cdot CTR_p \cdot TAP_p \cdot R_n}{1,000 \cdot kV_{LL} \cdot TR \left(1 - \frac{SLP}{100}\right)}}\right) \quad (50)$$

D. Summary

The equations derived previously are summarized in Table III.

TABLE III
87R WINDING COVERAGE QUICK-CHECK EQUATIONS FOR
DELTA-WYE LOW-IMPEDANCE GROUNDED TRANSFORMERS

Condition	Winding coverage check
No Load	$87R_C\% = 100 \cdot \left(1 - \sqrt{\frac{\sqrt{3} \cdot O87P \cdot CTR_p \cdot TAP_p \cdot R_n}{1,000 \cdot kV_{LL} \cdot TR}}\right)$
Rated Load	$87R_C\% = 100 \cdot \left(1 - \sqrt{\frac{\sqrt{3} \cdot \frac{SLP}{50} \cdot CTR_p \cdot TAP_p \cdot R_n}{1,000 \cdot kV_{LL} \cdot TR \left(1 - \frac{SLP}{100}\right)}}\right)$
Energization	$87R_C\% = 100 \cdot \left(1 - \sqrt{\frac{\sqrt{3} \cdot k_2 \cdot IOP_{2H} \cdot CTR_p \cdot TAP_p \cdot R_n}{1,000 \cdot kV_{LL} \cdot TR \left(1 - \frac{SLP}{100}\right)}}\right)$

IX. APPENDIX B: DERIVING REF WINDING COVERAGE FOR LOW-IMPEDANCE GROUNDED TRANSFORMERS

This section derives an equation to calculate the percentage of the wye winding that is protected against ground faults by the REF element described in Section IV.

During a ground fault on the wye winding of the transformer at a distance x pu from the neutral, the current I_{n_x} is given by (10), where I_{n100} is given by (8).

We can now solve for I_{n_x} by substituting (8) into (10) to get (51).

$$I_{n_x} = x \cdot \frac{\left(\frac{kV_{LL}}{\sqrt{3}}\right) \cdot 1,000}{R_n} \quad (51)$$

We can convert I_{n_x} to secondary amperes, as shown in (52).

$$I_{n_x}(\text{sec}) = x \cdot \frac{\left(\frac{kV_{LL}}{\sqrt{3}}\right) \cdot 1,000}{R_n \cdot CTRN} \quad (52)$$

The relay converts this measured current to pu by dividing by I_{NOM_CTRn} , as shown in (53).

$$I_{n_x}(\text{pu}) = x \cdot \frac{\left(\frac{kV_{LL}}{\sqrt{3}}\right) \cdot 1,000}{R_n \cdot CTRN \cdot I_{NOM_CTRn}} \quad (53)$$

For REF to assert during an internal ground fault, $I_{n_x}(\text{pu})$ must be greater than the 50NP pickup setting in the relay, as shown in (54).

$$I_{n_x}(\text{pu}) > 50NP \quad (54)$$

Substituting (53) into (54) and solving for x , we get (55).

$$x > \frac{50NP \cdot R_n \cdot CTRN \cdot I_{NOM_CTRN} \cdot \sqrt{3}}{kV_{LL} \cdot 1,000} \quad (55)$$

In percent of the total wye winding, (55) equates to (56).

$$x\% > 100 \cdot \frac{50NP \cdot R_n \cdot CTRN \cdot I_{NOM_CTRN} \cdot \sqrt{3}}{kV_{LL} \cdot 1,000} \quad (56)$$

The previous equation means that the REF element will operate for ground faults located above x percent of the winding, starting from the neutral. A more practical form of this equation is to calculate the percent of the winding protected by the REF element, starting from the terminal. This equation can be written as (57).

$$REF_C\% = 100 - x\% \quad (57)$$

Substituting (56) into (57), we get (58).

$$REF_C\% = 100 \cdot \left(1 - \frac{50NP \cdot R_n \cdot CTRN \cdot I_{NOM_CTRN} \cdot \sqrt{3}}{kV_{LL} \cdot 1,000} \right) \quad (58)$$

X. APPENDIX C: DERIVATIONS FOR EQUATIONS USED WHEN TESTING REF

In this section, we first calculate the minimum ground current required to perform a primary injection test for the REF element. Next, we calculate the required voltage and VA rating of the source.

A. Deriving the Minimum Current Requirement

The minimum primary current injected by the source must be the highest of the two values calculated using (16). In most REF installations, the CT ratio of the zone boundary CTs will be much larger than that of the ground CT. Therefore, the minimum current required for accurate metering in primary amperes for a 5 A nominal relay is given by (59).

$$I_{source} > 0.25 \cdot CTR_p \quad (59)$$

B. Deriving the Voltage Rating of the Source

Ohms law can be used to calculate the required voltage rating of the source. The minimum current requirement of the source in primary amperes is given by (59). The impedance of the transformer, $Z_T(\text{pu})$, is given on the nameplate in pu. To convert this to ohms, we can write (60) and (61).

$$Z_T = Z_T(\text{pu}) \cdot Z_{base} \quad (60)$$

$$Z_{base} = \frac{kV_{LL}^2}{MVA} \quad (61)$$

where:

MVA is the base power rating of the transformer (in MVA).

kV_{LL} is the rated wye-side line-to-line voltage (in kV).

Therefore, we can rewrite (60) as (62).

$$Z_T = Z_T(\text{pu}) \cdot \frac{kV_{LL}^2}{MVA} \quad (62)$$

Now that we know the impedance of the transformer in ohms, the required line-to-neutral voltage of the source is calculated by multiplying the transformer impedance in ohms by the minimum primary current required to get (63).

$$V_{source(LN)} = Z_T \cdot I_{source} \quad (63)$$

Substituting (62) and (59) into (63), we get the voltage rating of the source as (64).

$$V_{source(LN)} = Z_T(\text{pu}) \cdot \frac{kV_{LL}^2}{MVA} \cdot 0.25 \cdot CTR_p \quad (64)$$

C. Deriving the VA Rating of the Source

The minimum required VA rating of the source can be calculated using (65).

$$VA_{source} = V_{source(LN)} \cdot I_{source} \quad (65)$$

Expanded, this becomes (66).

$$VA_{source} = 0.1875 \cdot Z_T(\text{pu}) \cdot \frac{kV_{LL}^2}{MVA} \cdot CTR_p^2 \quad (66)$$

XI. REFERENCES

- [1] B. Kasztenny, M. Thompson, and N. Fischer, "Fundamentals of Short-Circuit Protection of Transformers," proceedings of the 63rd Annual Conference for Protective Relay Engineers, College Station, TX, March 2010.
- [2] IEEE Std C37.91, *IEEE Guide for Protecting Power Transformers*, 2021.
- [3] IEEE Std 242, *IEEE Recommended Practice for Protection and Coordination of Industrial and Commercial Power Systems*, 2001.
- [4] "Earth Fault Protection: How to Design Efficient Earth Fault Protection With Residual Current Devices (RCD)" Schneider Electric Guide, 2022. Available: se.com
- [5] T. Roseberg, I. Jankovic, and R. Hedding, "Transformer Tank Rupture – A Protection Engineer's Challenge" *IEEE*, proceedings of the 70th Annual Conference for Protective Relay Engineers, College Station, TX, 2017.
- [6] B. Edwards, D. G. Williams, A. Hargrave, M. Watkins, and V. K. Yedidi, "Beyond the Nameplate – Selecting Transformer Compensation Settings for Secure Differential Protection," proceedings of the 70th Annual Georgia Tech Protective Relaying Conference, Atlanta, GA, April 2016.
- [7] M. Thompson, "Percentage Restrained Differential, Percentage of What?," *IEEE*, proceedings of the 37th Annual Western Protective Relay Conference, College Station, TX, October 2010.
- [8] A. Guzman, H. Altuve, and D. Tziouvaras, "Power Transformer Protection Improvements With Numerical Relays," proceedings of the CIGRE Study Committee B5 Colloquium, Calgary, Canada, September 2005.
- [9] *Network Protection & Automation Guide: Protective Relays, Measurement & Control*, Alstrom Grid, 2011.
- [10] B. Rigby, A. Dierks, G. Tishenin, and T. Hensler, "Testing Sensitivity of Restricted Earth Fault Protection by Simulation of Faults Inside Transformers," *IEEE*, proceedings of the 15th International Conference on Developments in Power System Protection, Liverpool, UK, 2020.
- [11] R. Jogaib, R. Lehnemann, R. Abboud, and P. Lima, "Autotransformer Protection Case Studies, Going Above and Beyond the Traditional Cookbook," proceedings of the 49th Annual Western Protective Relay Conference, Spokane, WA, October 2022.
- [12] M. Gholami, E. Hajipour, and M. Vakilian, "High Impedance Restricted Earth Fault Protection: Fundamental Concepts, Design and Performance," proceedings of the 24th annual Iranian Conference on Electrical Engineering, Shiraz, Iran, 2016.

- [13] *SEL-387E Current Differential and Voltage Relay Instruction Manual*. Available: selinc.com
- [14] *SEL-487E-3, -4 Transformer Protection Relay and SEL-400 Series Relays Instruction Manual*. Available: selinc.com
- [15] *SEL-787-2, -3, -4 Transformer Protection Relays Instruction Manual*. Available: selinc.com
- [16] R. Chowdhury, M. Alla, N. Fischer, and S. Samineni, "Restricted Earth Fault Protection in Low-Impedance Grounded Systems With Inverter-Based Resources," *IEEE Transactions on Power Delivery*, Vol. 38, No. 1, February 2023, pp. 505–512.
- [17] R. Chowdhury, R. McDaniel, and N. Fischer, "Applying Line Current Differential Protection in Systems With Inverter-Based Resources," Schweitzer Engineering Laboratories Inc., Pullman, WA, March 2022.
- [18] R. Patterson, "Pinhook 500kV Transformer Neutral CT Saturation," proceedings of the 9th Annual Fault and Disturbance Analysis Conference, Atlanta, GA, May 2006.
- [19] M. Thompson, F. K. Basha, and C. Holt, "Modern Protection of Three-Phase and Spare Transformer Banks," *IEEE*, proceedings of the 60th Annual Conference for Protective Relay Engineers, College Station, TX, April 2016.
- [20] E. Atienza and M. Cooper, "Verifying Transformer Differential Compensation Settings," proceedings of the 67th Annual Georgia Tech Protective Relaying Conference, Atlanta, GA, May 2013.
- [21] S. Uddin, A. Bapary, M. Thompson, R. McDaniel, and K. Salunkhe, "Application Considerations for Protecting Transformers With Dual Breaker Terminals," proceedings of the 45th Annual Western Protective Relay Conference, Spokane, WA, October 2018.
- [22] M. Kao, G. Kobet, and G. Pitts, "Considerations and Experiences in Implementing Ground Differential Protection for Transformer Protection at TVA," proceedings of the 11th annual Georgia Tech Protective Relaying Conference, Atlanta, GA, April, 2009.
- [23] M. Thompson, J. Hostetler, A. Hargrave, and S. Sawai, "Stop the Epidemic! Transformer Protection Misoperations," proceedings of the 48th Annual Western Protective Relay Conference, Spokane, WA, October 2021.
- [24] IEEE Std C37.103, *IEEE Guide for Differential and Polarizing Relay Circuit Testing*, 2015.
- [25] O. Peterson, R. Scharlach, and C. Baltazar, "Proper Testing of Protection Systems Ensures Against False Tripping and Unnecessary Outages," proceedings of the Pulp and Paper Industry Technical Conference, Birmingham, Alabama, June 2009.
- [26] IEEE Std C57.13.1, *IEEE Guide for Differential and Polarizing Relay Circuit Testing*, 2015.
- [27] A. Hargrave, M. J. Thompson, and B. Heilman, "Beyond the Knee Point: A Practical Guide to CT Saturation" *IEEE*, 2018.
- [28] C. D. Hayward, "Relays for Transformer Differential Protection" *Electrical Engineering*, Vol. 60, No. 6, June 1941, pp. 377–382.

XII. BIOGRAPHIES

Swagata Das earned her B.Tech degree from SRM University in Chennai, India, in 2009. She graduated with her MSE and PhD degrees in electrical engineering from the University of Texas, Austin, in 2011 and 2015, respectively. Swagata joined Schweitzer Engineering Laboratories, Inc. (SEL) in 2015 and works as a protection application engineer in Boerne, Texas. She received the Walter A. Elmore Best Paper Award from the Georgia Institute of Technology Protective Relaying Conference in 2017. She is a senior IEEE member and a registered professional engineer in the state of Texas.

Ariana Hargrave earned her BSEE, magna cum laude, from St. Mary's University in San Antonio, Texas, in 2007. She graduated with a master of engineering degree in electrical engineering from Texas A&M University in 2009, specializing in power systems. Ariana joined Schweitzer Engineering Laboratories, Inc. (SEL) in 2009 and works as a senior protection application engineer in Boerne, Texas. She has published over 30 application guides and technical papers and was honored to receive the Walter A. Elmore Best Paper Award from the Georgia Institute of Technology Protective Relaying Conference in 2017 and 2018. She is a senior IEEE member and a registered professional engineer in the state of Texas.

Marcel Taberer joined Schweitzer Engineering Laboratories, Inc. (SEL) as an application engineer in 2016. He previously worked for Eskom, a power utility company in South Africa, as a protection engineering technologist for nine years. He was responsible for commissioning and testing primary and secondary plant equipment in the distribution and transmission sector within the Eastern Cape. He earned his Bachelor of Technology degree from Cape Peninsula University of Technology and his Master of Technology degree from Nelson Mandela Metropolitan University in Cape Town and Port Elizabeth, South Africa, respectively. He is an IEEE senior member and a registered professional engineer in the state of Texas.

Michael J. Thompson received his BS, magna cum laude, from Bradley University in 1981 and an MBA. from Eastern Illinois University in 1991. Upon graduating, he served nearly 15 years at Central Illinois Public Service (now AMEREN). Prior to joining Schweitzer Engineering Laboratories, Inc. (SEL) in 2001, he worked at Basler Electric. He is presently a Fellow Engineer at SEL Engineering Services, Inc. He is a senior member of the IEEE, Chairman of the IEEE PES Power System Relaying and Control Committee, past chairman of the Substation Protection Subcommittee of the PSRC and received the Standards Medallion from the IEEE Standards Association in 2016. He is also a subject matter expert advising the System Protection and Control Working Group of the North American Electric Reliability Corporation. Michael is a registered professional engineer in six jurisdictions, was a contributor to the reference book, *Modern Solutions for the Protection Control and Monitoring of Electric Power Systems*, has published numerous technical papers and magazine articles, and holds three patents associated with power system protection and control.